

REVISIONS			
REV	DESCRIPTION, ECN, EAR NO.	DATE	APP'D
B	PROPOSAL	29-SEP-22	OK
B	UPDATED PIN NUMBER	04-NOV-22	OK

AMPHENOL PART NUMBER CONFIGURATION
V 6 2 - C D Z 0 1 - 0 4 0 0 X X 1

PLATING OPTION

- 2 - 0.76µm GOLD AT MATING AREA
GOLD FLASH ON TERMINATION
- 3 - 76µm GOLD AT MATING AREA
2.54-7.62µm MATTE TIN ON TERMINATION
- 5 - 0.38µm GOLD AT MATING AREA
GOLD FLASH ON TERMINATION
- 6 - 0.38µm GOLD AT MATING AREA
2.54-7.62µm MATTE TIN ON TERMINATION

PACKAGING

- 1 - T&R PACKAGING
(STANDARD CONNECTOR ORIENTATION)

SOLDER RING CONFIGURATION

- 0 - WITHOUT SOLDER RING
- 1 - WITH SOLDER RING

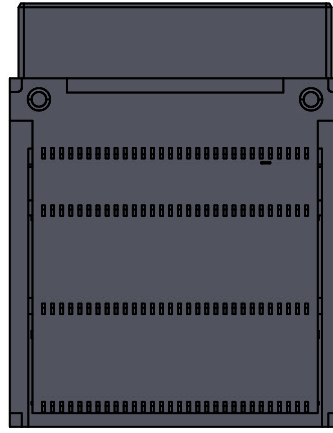
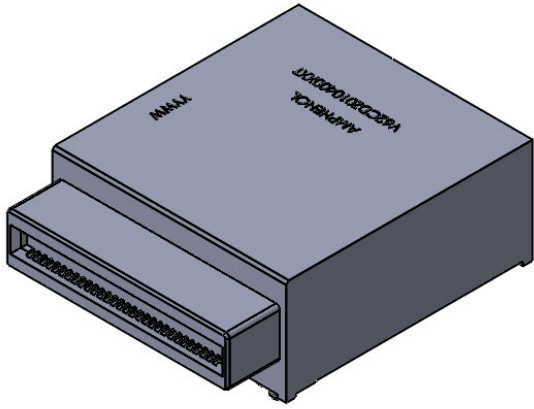

V62-CDZ01-0400X0T
(WITHOUT SOLDER RING
FOR SINGLE SIDE MOUNTING)

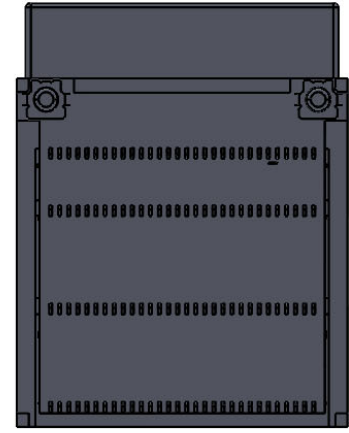

V62-CDZ01-0400X1T
(WITH SOLDER RING FOR
BELLY TO BELLY MOUNTING)

NOTES:

1. MATERIAL:

- HOUSING: SOLDER REFLOW PROCESS COMPATIBLE LCP, UL 94 V-0
- CONTACTS: COPPER ALLOY, PLATING: SEE PART NUMBER CONFIGURATION
- SOLDER RINGS: COPPER ALLOY. PLATING: MATTE TIN PLATED

2. ROHS COMPLIANT



UNLESS SPECIFIED OTHERWISE	DRAWN	KHALID H	09-28-2022
PRIMARY UNITS MILLIMETERS	CHECKED	BA P	09-29-2022
SECONDARY INCHES	M.E. APP'D	XX	XX
REFERENCE IN PARENTHESES	Q.A. APP'D	XX	XX
GENERAL TOLERANCES	DWG APP'D	OMER K	09-29-2022
1 DECIMAL PLACE ±0.15	ENG. REL. NO.	ECN EXXXXX	
2 DECIMAL PLACES ±0.10	REF.		
3 DECIMAL PLACES ±0.050	THIRD ANGLE PROJECTION		
ANGULAR DEGREES ±0.5°	DO NOT SCALE DRAWING		

Amphenol High Speed Interconnects
A Division of Amphenol Corp. www.amphenolcanada.com

OSFP-XD 1X1 CONNECTOR

DWG. NO.	P-V62-CDZ01-0400XT	REV	B
CODE ID NO.	03554	DWG SIZE:	C
SCALE:	5:1	SHEET 1 OF 4	

REVISIONS			
REV	DESCRIPTION, ECN, EAR NO.	DATE	APPD
B	SEE SHEET 1	29-SEP-22	OK

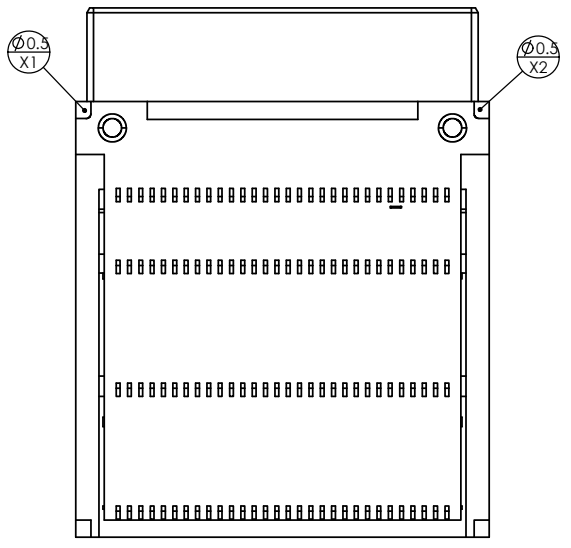
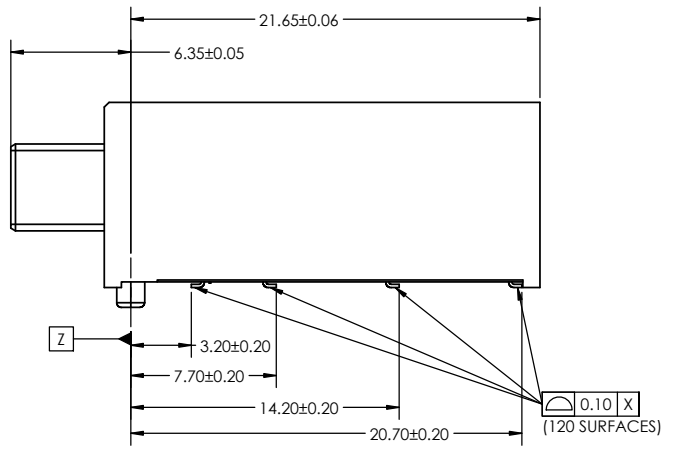
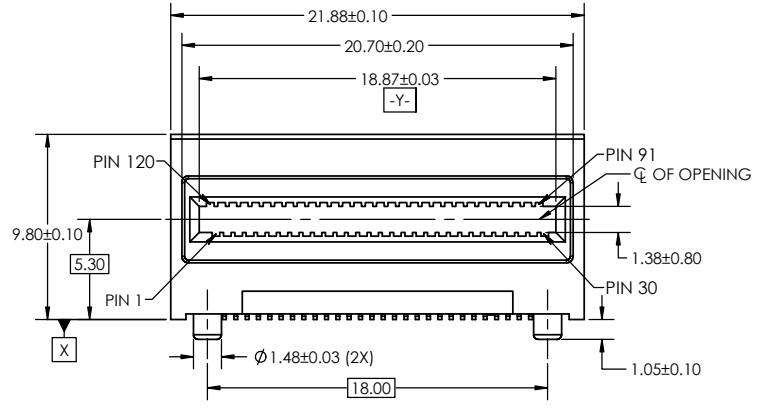

UNLESS SPECIFIED OTHERWISE	DRAWN	KHALID H	09-28-2022
PRIMARY UNITS MILLIMETERS	CHECKED	BA P	09-29-2022
SECONDARY INCHES	M.E. APPD	XX	XX
REFERENCE IN PARENTHESES	Q.A. APPD	XX	XX
GENERAL TOLERANCES	DWG APPD	OMER K	09-29-2022
1 DECIMAL PLACE ±0.15	ENG. REL. NO.	ECN EXXXXX	
2 DECIMAL PLACES ±0.10	REF.		
3 DECIMAL PLACES ±0.050	THIRD ANGLE PROJECTION		
ANGULAR DEGREES ±0.5°	DO NOT SCALE DRAWING		

Amphenol High Speed Interconnects A Division of Amphenol Corp. www.amphenolcanada.com			
OSFP-XD 1X1 CONNECTOR			
DWG. NO.	P-V62-CDZ01-0400XXT		REV B
CODE ID NO.	03554	DWG SIZE: C	SCALE: 5:1 SHEET 2 OF 4

THIS DOCUMENT CONTAINS PROPRIETARY INFORMATION AND SUCH INFORMATION MAY NOT BE DISCLOSED TO OTHERS FOR ANY PURPOSE OR USED FOR MANUFACTURING PURPOSES WITHOUT WRITTEN PERMISSION FROM AMPHENOL CANADA CORP.

NOTES:

1. PIN ASSIGNMENT: SEE MSA FOR DETAIL.

REVISIONS			
REV	DESCRIPTION, ECN, EAR NO.	DATE	APP'D
B	SEE SHEET 1	29-SEP-22	OK

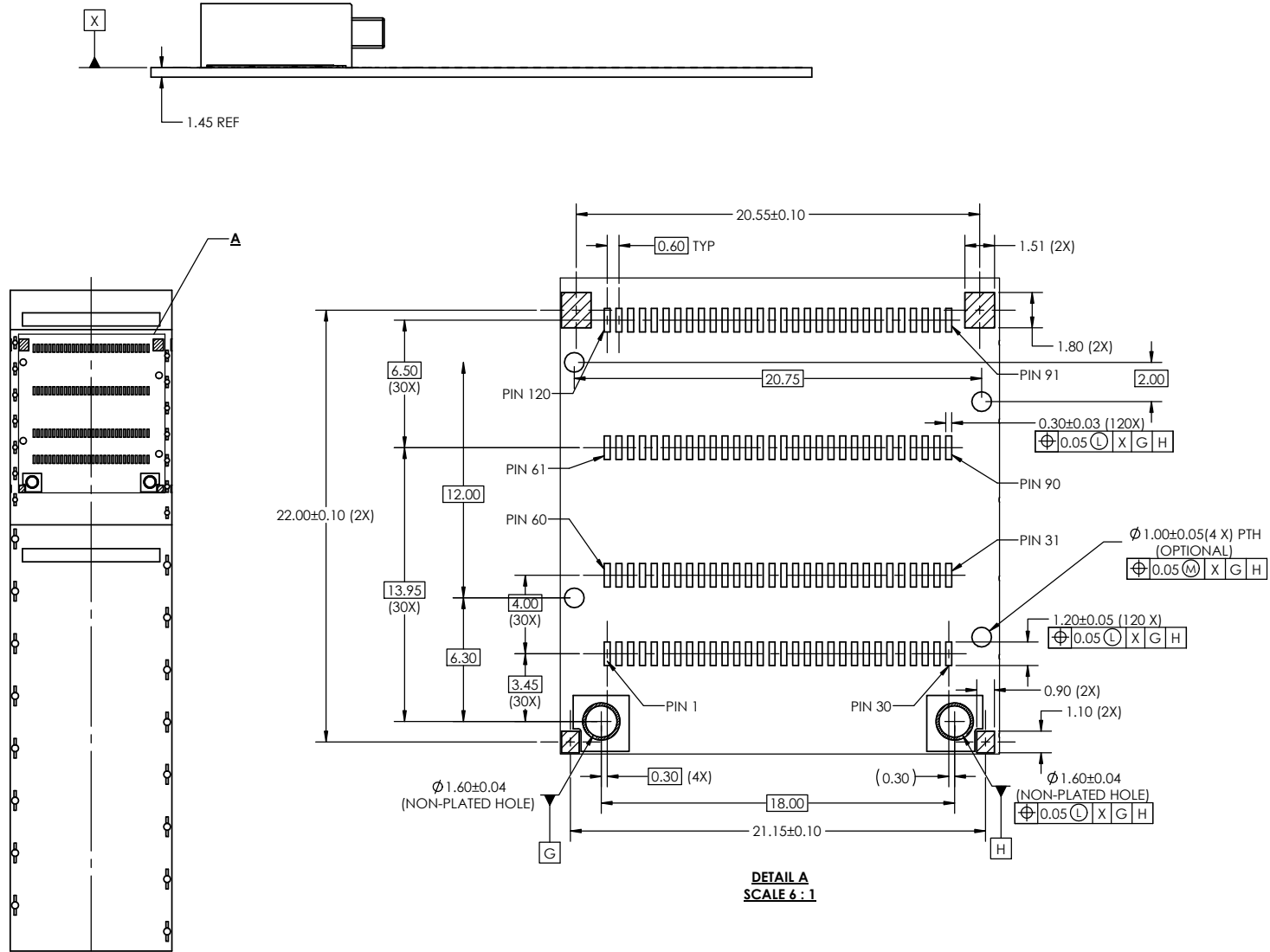

RECOMMENDED PCB LAYOUT FOR SINGLE SIDE MOUNTING



UNLESS SPECIFIED OTHERWISE	DRAWN	KHALID H	09-28-2022
PRIMARY UNITS MILLIMETERS	CHECKED	BA P	09-29-2022
SECONDARY INCHES	M.E. APP'D	XX	XX
REFERENCE IN PARENTHESES	Q.A. APP'D	XX	XX
GENERAL TOLERANCES	DWG APP'D	OMER K	09-29-2022
1 DECIMAL PLACE ±0.15	ENG. REL. NO.	ECN EXXXXX	
2 DECIMAL PLACES ±0.10	REF.		
3 DECIMAL PLACES ±0.050	THIRD ANGLE PROJECTION		
ANGULAR DEGREES ±0.5°	DO NOT SCALE DRAWING		

Amphenol High Speed Interconnects
A Division of Amphenol Corp. www.amphenolcanada.com

OSFP-XD 1X1 CONNECTOR

DWG. NO.	P-V62-CDZ01-0400XXT	REV	B
CODE ID NO.	03554	DWG SIZE:	C
SCALE:	2:1	SHEET	3 OF 4

REVISIONS			
REV	DESCRIPTION, ECN, EAR NO.	DATE	APP'D
B	SEE SHEET 1	29-SEP-22	OK

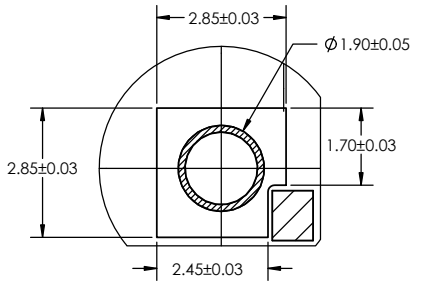
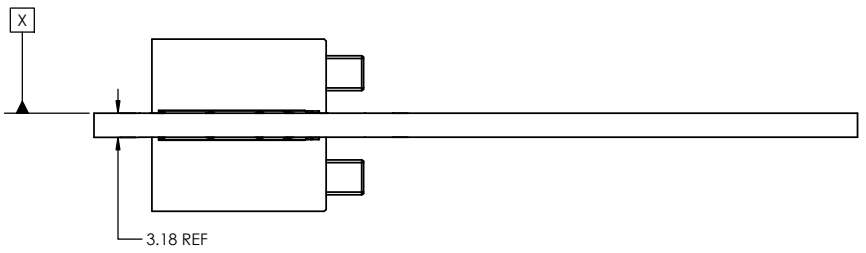

**PADS FOR SOLDER RINGS
(2 PLCS)
DETAIL D
SCALE 12 : 1**

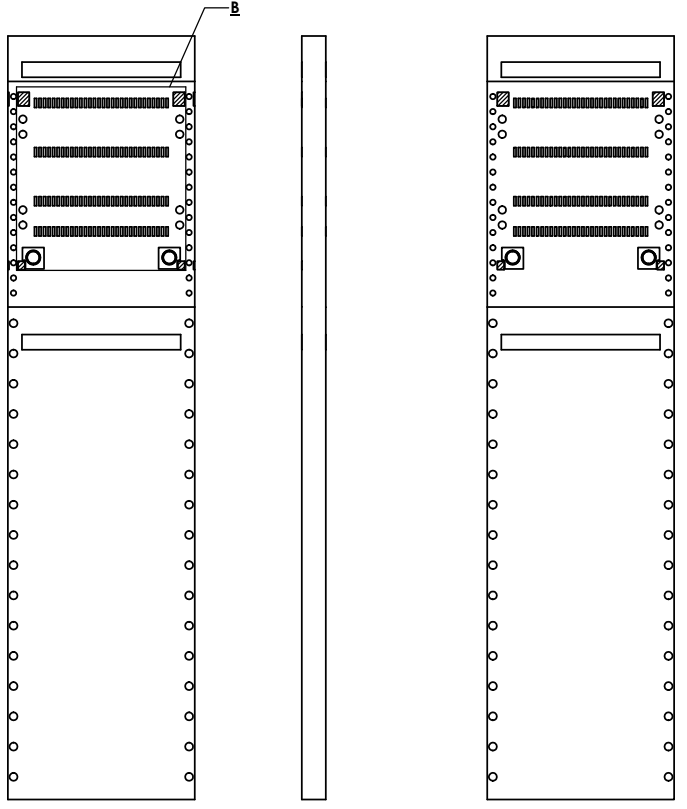

RECOMMENDED PCB LAYOUT FOR BELLY TO BELLY MOUNTING

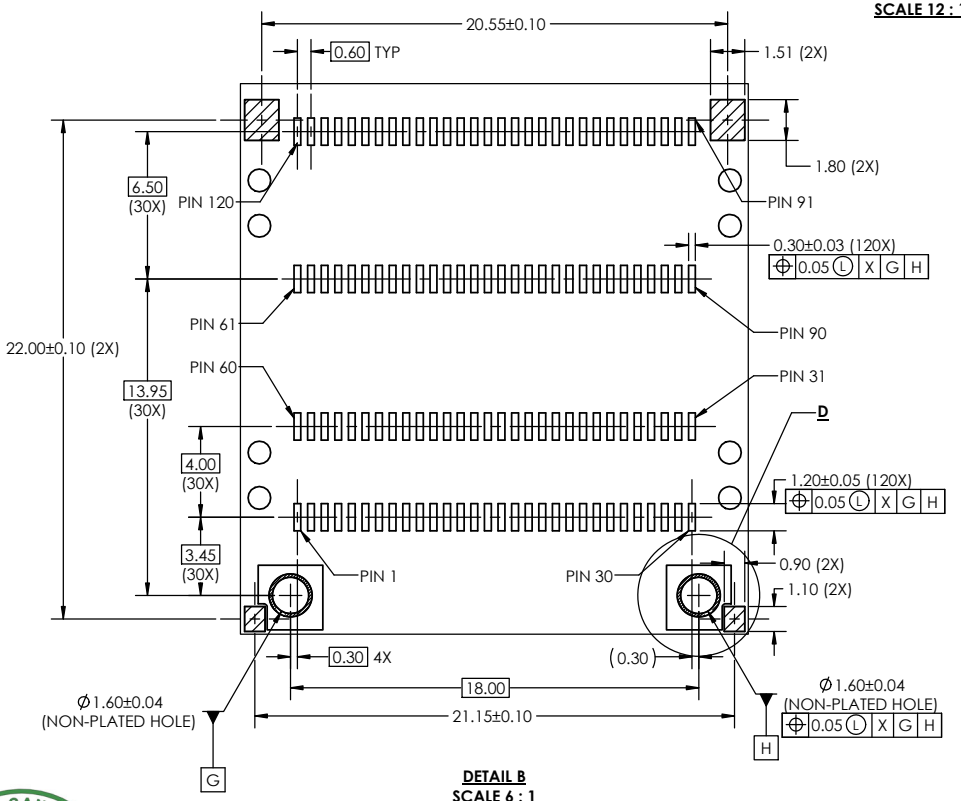

**DETAIL B
SCALE 6 : 1**



UNLESS SPECIFIED OTHERWISE	DRAWN	KHALID H	09-28-2022
PRIMARY UNITS MILLIMETERS	CHECKED	BA P	09-29-2022
SECONDARY INCHES	M.E. APP'D	XX	XX
REFERENCE IN PARENTHESES	Q.A. APP'D	XX	XX
GENERAL TOLERANCES	DWG APP'D	OMER K	09-29-2022
1 DECIMAL PLACE ±0.15	ENG. REL. NO.	ECN EXXXXX	
2 DECIMAL PLACES ±0.10	REF.		
3 DECIMAL PLACES ±0.050	THIRD ANGLE PROJECTION		
ANGULAR DEGREES ±0.5°	DO NOT SCALE DRAWING		

Amphenol High Speed Interconnects A Division of Amphenol Corp. www.amphenolcanada.com			
OSFP-XD 1X1 CONNECTOR			
DWG. NO.	P-V62-CDZ01-0400XXT		REV B
CODE ID NO.	03554	DWG SIZE: C	SCALE: 1:1 SHEET 4 OF 4