

- NOTES:
- ELECTRICAL AND MECHANICAL PERFORMANCE SHOULD MEET THE PCIe GNE 5 INDUSTRIAL STANDARD.
 - 电气和机械特性满足 PCIe GNE 5 工业标准。
 - THE CABLE ASSEMBLY SHOULD BE RoHS COMPLIANT.
 - 该产品符合RoHS。
 - THE CABLE ASSEMBLY SHALL MEET BELOW IMPEDANCE REQUIREMENT:
 - TERMINATION AREA: $85 \pm 15\%$ OHMS, CABLE ABSOLUTE AREA: $85 \pm 10\%$ OHMS.
 - 该产品满足下面阻抗特性: 接触区域 $85 \pm 15\%$ 欧姆, 线材为 $85 \pm 10\%$ 欧姆。

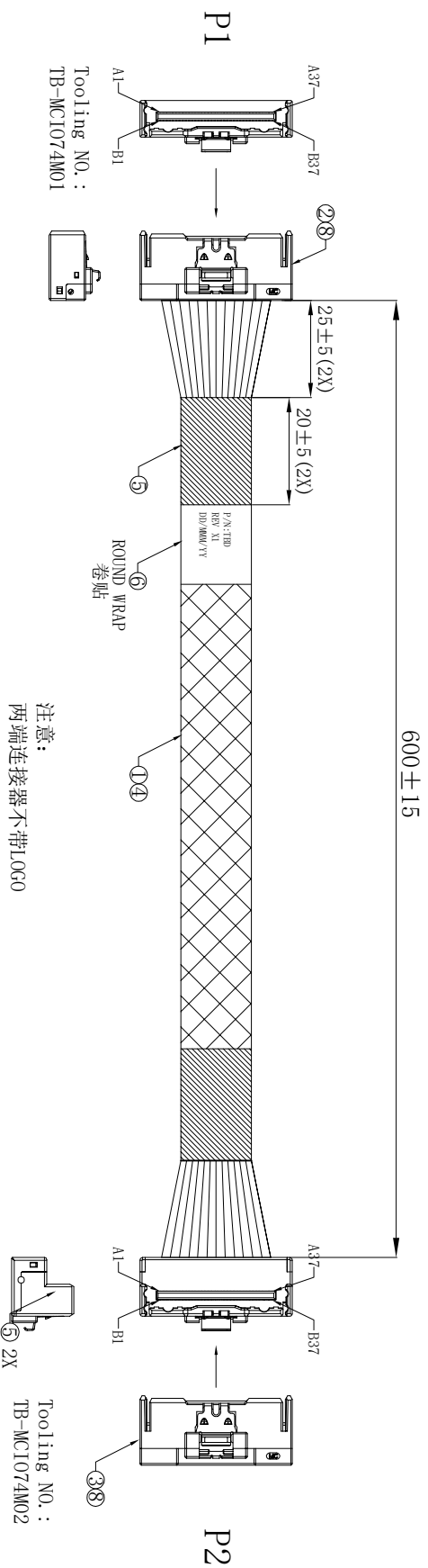

注意:
两端连接器不带LOGO

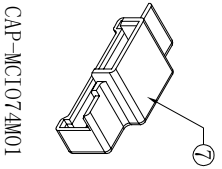
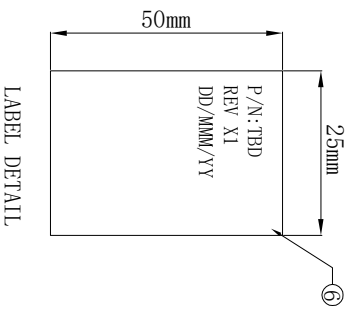

8	605011715	LV胶, 型号2820R, 低介电, 50ML, HF	A/R	BOT
7	602010105	LOW DENSITY PE, QWPCQ, PD4F4, NATURA, R2	A/R	KG
6	604100070	LABEL: PVC, 25*50mm, WHITE, R3BS	1	PCS
5	605011630	POLYESTER TAPE: T=0.12mm, W=20mm, BLACK, HF	A/R	mm
4	605040427	EXPANDO TUBE: OD=10.0mm, BLACK, W=1, R3BS	A/R	mm
3	TBD	MCI0 RA 12I 85Ω W/O LOGO	1	PCS
2	TBD	MCI0 STR 12I 85Ω W/O LOGO	1	PCS
1	603010264	SAS CBL: 30#*2C+2EAM, 镀银铜, 85Ω, W=1, 蓝, HF, P5	A/R	mm
ITEM	P/N	DESCRIPTION	QTY	UNIT

QUALITY SYMBOLS

□: MAJOR

∇: CRITICAL

∇: ZERO DEFECT S.P.C

Tolerance

X: ±0.50

.X: ±0.30

.XX: ±0.15

NAME: MCI0 12I STR-RA Cable 0.6M P5

REV: A UNIT: mm

SCALE: N:1 DATE: 2022/12/09

DRW BY: DAW NHU

CHK BY: KING ZHOU

PART NO. TBD

APP BY: 151-30737

东莞市箐园电子有限公司

△									
△	2022/12/09	新版发行	King Zhou						
△	DATE	DESCRIPTION	APPROVER	ZERO DEFECT	S.P.C				
8	7	6	5	4	3	2	1		

Connection relationship:

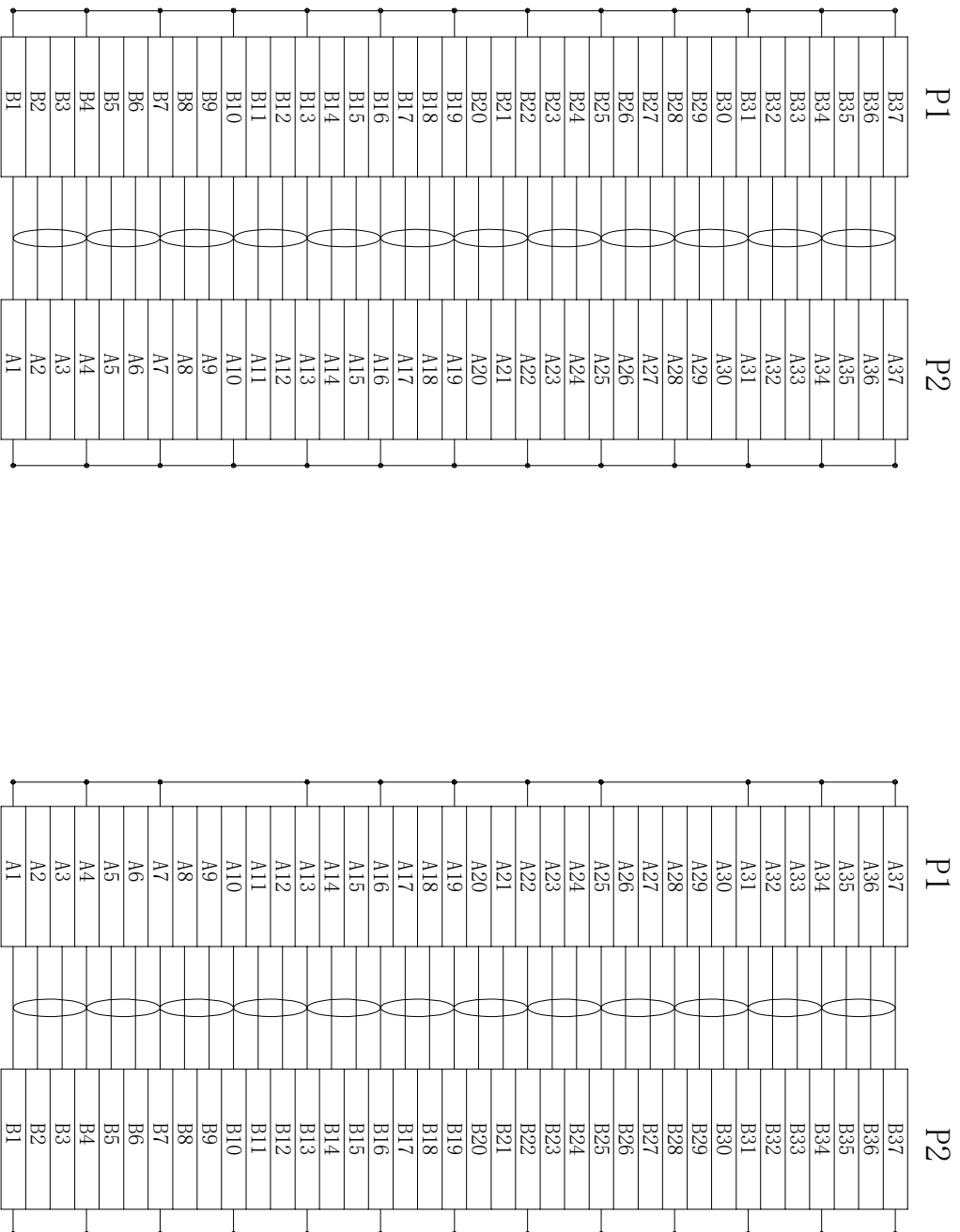

A		B		C		D		E		F																																																																	
<table border="1"> <tr> <td>△</td> <td></td> <td></td> <td></td> <td></td> <td></td> <td></td> <td></td> <td></td> <td></td> <td></td> <td></td> </tr> <tr> <td>△</td> <td></td> <td></td> <td></td> <td></td> <td></td> <td></td> <td></td> <td></td> <td></td> <td></td> <td></td> </tr> <tr> <td>△</td> <td>2022/12/09</td> <td>新版发行</td> <td>King Zhou</td> <td>QUALITY SYMBOLS</td> <td> <input type="checkbox"/> : <input checked="" type="checkbox"/> : CRITICAL MAJOR ZERO DEFECT S.P.C </td> <td>Tolerance</td> <td> x: ±0.50 .x: ±0.30 .xx: ±0.15 </td> <td>NAME: MCIO 121 STR-RA Cable 0.6M P5</td> <td>PART NO.</td> <td>TBD</td> <td>DRAWING NO.</td> </tr> <tr> <td>SIDE</td> <td>DATE</td> <td>DESCRIPTION</td> <td>APPROVER</td> <td colspan="2"></td> <td colspan="2"> </td> <td>REV: A</td> <td>UNIT: mm</td> <td>DRW BY: DRW NHU</td> <td>CHK BY: KING ZHOU</td> <td>APP BY:</td> </tr> <tr> <td>8</td> <td></td> <td></td> <td></td> <td colspan="2"></td> <td colspan="2"></td> <td>SCALE: N:1</td> <td>DATE: 2022/12/09</td> <td>DAW NHU</td> <td></td> <td>151-30737</td> </tr> </table>		△												△												△	2022/12/09	新版发行	King Zhou	QUALITY SYMBOLS	<input type="checkbox"/> : <input checked="" type="checkbox"/> : CRITICAL MAJOR ZERO DEFECT S.P.C	Tolerance	x: ±0.50 .x: ±0.30 .xx: ±0.15	NAME: MCIO 121 STR-RA Cable 0.6M P5	PART NO.	TBD	DRAWING NO.	SIDE	DATE	DESCRIPTION	APPROVER					REV: A	UNIT: mm	DRW BY: DRW NHU	CHK BY: KING ZHOU	APP BY:	8								SCALE: N:1	DATE: 2022/12/09	DAW NHU		151-30737	6		5		4		3		2		1	
△																																																																											
△																																																																											
△	2022/12/09	新版发行	King Zhou	QUALITY SYMBOLS	<input type="checkbox"/> : <input checked="" type="checkbox"/> : CRITICAL MAJOR ZERO DEFECT S.P.C	Tolerance	x: ±0.50 .x: ±0.30 .xx: ±0.15	NAME: MCIO 121 STR-RA Cable 0.6M P5	PART NO.	TBD	DRAWING NO.																																																																
SIDE	DATE	DESCRIPTION	APPROVER					REV: A	UNIT: mm	DRW BY: DRW NHU	CHK BY: KING ZHOU	APP BY:																																																															
8								SCALE: N:1	DATE: 2022/12/09	DAW NHU		151-30737																																																															
A		B		C		D		E		F																																																																	

东莞市箐国电子有限公司