

8 7 6 5 4 3 2 1

REVISIONS				
REV.	ECN	DESCRIPTION	DATE	APPROVED
F		ADDED HEAT SINK OPTION TABLE	DEC17/14	CM
G		ADDED DUST COVER OPTION	APR16/15	CM
H		PART NUMBER AND DATE CODE MARKING ADDED	AUG22/16	CM

AMPHENOL PART NUMBER CONFIGURATION
U98 - B 1 X X - X X X X

HEAT SINK OPTION
SEE SHEET 4

INSULATING TAPE OPTION
1 = STANDARD (NO INSULATING TAPE)
2 = WITH INSULATING TAPE ON BOTTOM CAGE

PLATING
1 = NICKEL

DUST COVER OPTION
0 = WITHOUT DUST COVER
D = WITH DUST COVER (PACKAGED SEPARATELY)

PACKAGING
1 = TRAY PACKAGING

CONNECTOR COVER
0 = WITH CONNECTOR COVER, NO KICKOUT SPRING
A = WITHOUT CONNECTOR COVER OR KICKOUT SPRING
B = WITHOUT CONNECTOR COVER, WITH KICKOUT SPRING
C = WITH CONNECTOR COVER & KICKOUT SPRING

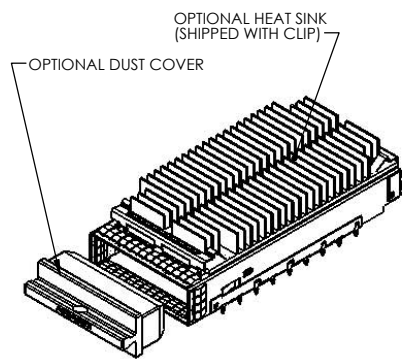

SCALE 1:1.5
VIEW OF CAGE ASSEMBLY WITH STANDARD HEAT SINK AND CLIP ASSEMBLED, WITH DUST COVER, WITHOUT CONNECTOR COVER OR KICKOUT SPRING (P/N U98-B121-1DA1)

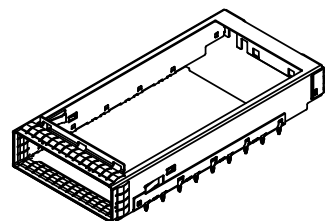

SCALE 1:1.5
VIEW OF CAGE ASSEMBLY WITHOUT HEAT SINK AND CLIP, WITHOUT CONNECTOR COVER OR KICKOUT SPRING (P/N U98-B111-10A1)

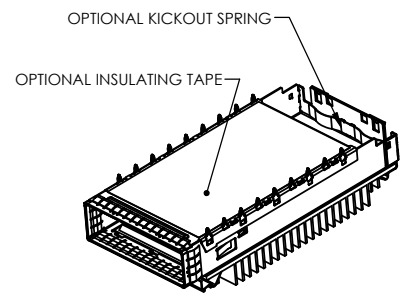

SCALE 1:1.5
BOTTOM VIEW OF CAGE ASSEMBLY WITH STANDARD HEAT SINK, KICK-OUT SPRING, AND INSULATING TAPE OPTION, WITHOUT CONNECTOR COVER (P/N U98-B122-10B1)

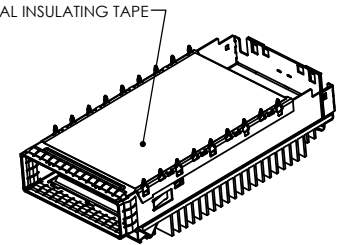

SCALE 1:1.5
BOTTOM VIEW OF CAGE ASSEMBLY WITH STANDARD HEAT SINK AND INSULATING TAPE OPTION, WITHOUT CONNECTOR COVER OR KICK-OUT SPRING (P/N U98-B122-10A1)

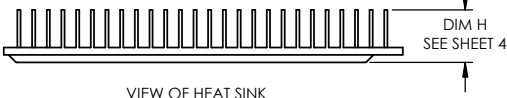
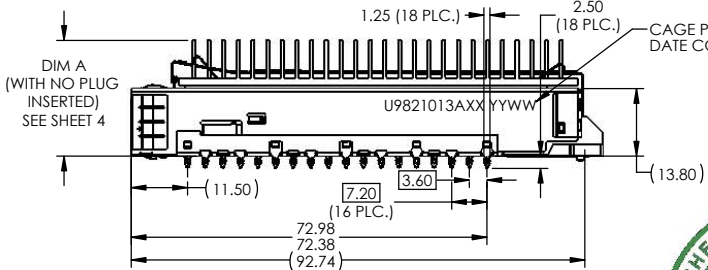
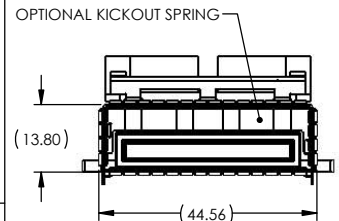

VIEW OF HEAT SINK

DO NOT SCALE DRAWING

THIS DOCUMENT CONTAINS PROPRIETARY INFORMATION AND SUCH INFORMATION MAY NOT BE DISCLOSED TO OTHERS FOR ANY PURPOSE OR USED FOR MANUFACTURING PURPOSES WITHOUT PERMISSION FROM AMPHENOL CANADA CORP.



NOTES:

- CAGE AND EMI SPRINGS MATERIAL: COPPER ALLOY
HEAT SINK CLIP MATERIAL: STEEL ALLOY
HEAT SINK MATERIAL: ALUMINUM
CONNECTOR COVER: ZINC ALLOY
INSULATING TAPE: POLYIMIDE FILM
CAGE PLATING: 3.81µm (100µin) MIN. NICKEL
DUST COVER: CONDUCTIVE RUBBER
- CAGE IS INTENDED TO BE COMPLIANT WITH THE CFP2 TRANSCEIVER SPECIFICATION.
- M1.4 STEEL SCREWS (4 PCS) ARE INCLUDED WITH CONNECTOR COVER OPTIONS (PACKAGED SEPARATELY). RECOMMENDED TORQUE IS 0.90±0.10in.-lb.

UNLESS OTHERWISE SPECIFIED DIMENSIONS ARE IN MILLIMETERS TOLERANCES ARE:		APPROVALS		DATE		Amphenol High Speed Interconnects	
DECIMALS	ANGLES	DRAWN	T. LOLOPADE		JAN11/13		TITLE
XX ± 0.15	± 0.5°	DESIGNED	C. MICHLIK		JUN05/12		CFP2 SINGLE PORT CAGE ASSEMBLY WITH PRESS FIT PINS
X.XX ± 0.10		CHECKED	C. MICHLIK		OCT07/13		
MATERIAL AND FINISH		GA APPD					
SEE NOTE 1		E APPD				SIZE A3 DWG. NO. P-U98-B1XX-XXXX REV. H	
REF.		DWG APPD		C. MICHLIK		SCALE 1:1 PROJECT SHEET 1 OF 4	
CODE IDENT. NO.	03554			OCT07/13			

8 7 6 5 4 3 2 1

REVISIONS				
REV.	ECN	DESCRIPTION	DATE	APPROVED
H		SEE SHEET 1	AUG22/16	CM

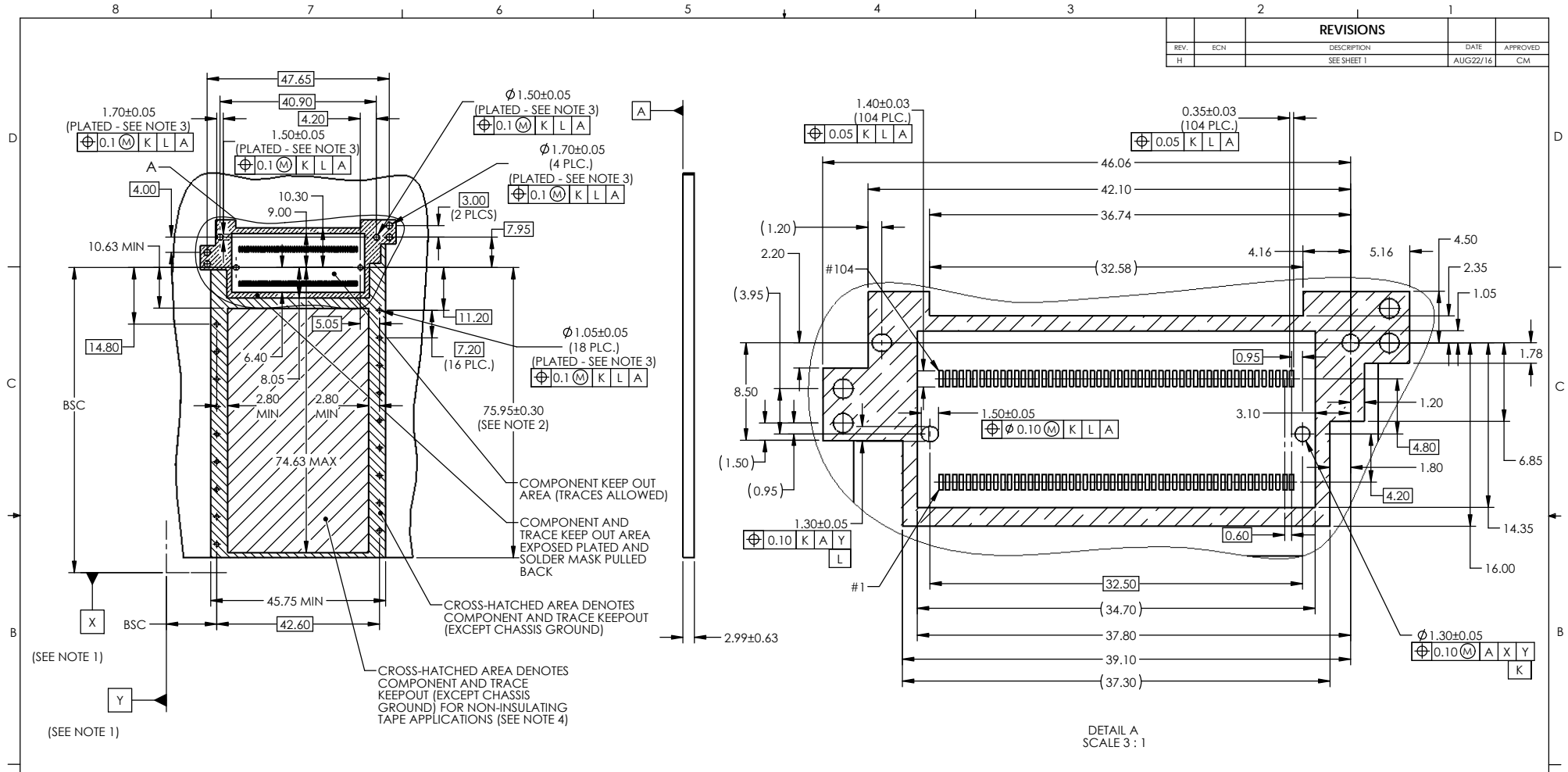

RECOMMENDED PC BOARD LAYOUT
(COMPONENT SIDE OF BOARD)

DETAIL A
SCALE 3 : 1

NOTES:

- DATA X AND Y ESTABLISHED BY CUSTOMER'S FIDUCIAL.
- LOCATION OF EDGE OF PCB IS APPLICATION SPECIFIC.
- FINISHED HOLE SIZE.
- COMPONENTS AND TRACES IN INDICATED AREA ARE ONLY ALLOWED FOR APPLICATIONS WITH INSULATING TAPE

DO NOT SCALE DRAWING

THIS DOCUMENT CONTAINS PROPRIETARY INFORMATION AND SUCH INFORMATION MAY NOT BE DISCLOSED TO OTHERS FOR ANY PURPOSE OR USED FOR MANUFACTURING PURPOSES WITHOUT PERMISSION FROM AMPHENOL CANADA CORP.

UNLESS OTHERWISE SPECIFIED DIMENSIONS ARE IN MILLIMETERS TOLERANCES ARE: DECIMALS ANGLES XX ± 0.15 ± 0.5° X.XX ± 0.10	APPROVALS	DATE	Amphenol High Speed Interconnects	
	DRAWN: T. LOLOPADE	JAN11/13	TITLE	
	DESIGNED: C. MICHLIK	JUN05/12	CFP2 SINGLE PORT CAGE ASSEMBLY WITH PRESS FIT PINS	
	CHECKED: C. MICHLIK	OCT07/13	GA APPD	
MATERIAL AND FINISH	SEE NOTE 1		E APPD	
REF.	E APPD		SIZE: A3	DWG. NO: P-U98-B1XX-XXXX
CODE IDENT. NO. 03554	DWG APPD: C. MICHLIK	OCT07/13	SCALE: 1:1	PROJECT
				REV: H
				SHEET 2 OF 4

REVISIONS				
REV.	ECN	DESCRIPTION	DATE	APPROVED
H		SEE SHEET 1	AUG22/16	CM

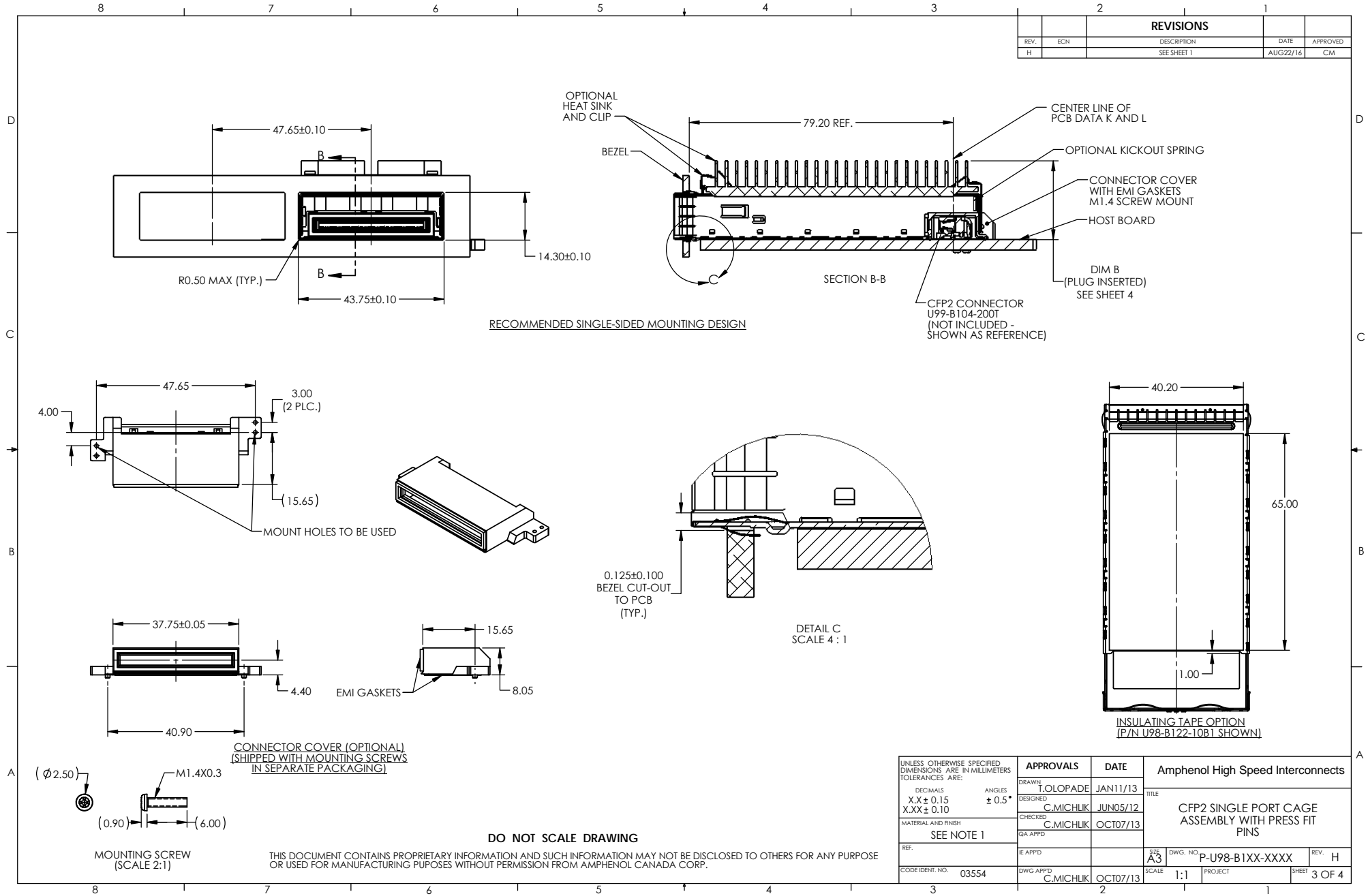

UNLESS OTHERWISE SPECIFIED DIMENSIONS ARE IN MILLIMETERS TOLERANCES ARE: DECIMALS .XX ± 0.15 X.XX ± 0.10 MATERIAL AND FINISH SEE NOTE 1 REF. CODE IDENT. NO. 03554	APPROVALS	DATE	Amphenol High Speed Interconnects TITLE CFP2 SINGLE PORT CAGE ASSEMBLY WITH PRESS FIT PINS SIZE A3 DWG. NO. P-U98-B1XX-XXXX REV. H SCALE 1:1 PROJECT SHEET 3 OF 4	
	DRAWN: T. LOLOPADE	JAN11/13		
	DESIGNED: C. MICHLIK	JUN05/12		
	CHECKED: C. MICHLIK	OCT07/13		
	GA APPD			
	E APPD			
	DWG APPD: C. MICHLIK	OCT07/13		

REVISIONS				
REV.	ECN	DESCRIPTION	DATE	APPROVED
H		SEE SHEET 1	AUG22/16	CM

HEAT SINK OPTION	GEOMETRY	MATERIAL	PLATING	CLIP	DIM A SHT 1 B7	DIM B SHT 3 A2	DIM H SHT 1 A5
1	NO HEAT SINK	N/A	N/A	NO	N/A	N/A	N/A
2	FIN, SIDE TO SIDE	ALUMINUM ALLOY	BLACK HARD COAT ANODIZE	YES	23.00	23.65	10.75
4	FIN, SIDE TO SIDE	ALUMINUM ALLOY	BLACK HARD COAT ANODIZE	YES	20.00	20.65	7.75
D	FIN, FRONT TO BACK	ALUMINUM ALLOY	NICKEL PLATING	YES	23.00	23.65	10.75
M	FIN, FRONT TO BACK	ALUMINUM ALLOY	BLACK HARD COAT ANODIZE	YES	23.00	23.65	10.75

UNLESS OTHERWISE SPECIFIED DIMENSIONS ARE IN MILLIMETERS TOLERANCES ARE:		APPROVALS		DATE		Amphenol High Speed Interconnects	
DECIMALS: X.X ± 0.15 X.XX ± 0.10		DRAWN: T. LOLOPADE		JAN11/13			
ANGLES: ± 0.5°		DESIGNED: C. MICHLIK		JUN05/12		CFP2 SINGLE PORT CAGE ASSEMBLY WITH PRESS FIT PINS	
MATERIAL AND FINISH: SEE NOTE 1		CHECKED: C. MICHLIK		OCT07/13			
REF:		GA APPD:		SIZE: A3		DWG. NO: P-U98-B1XX-XXXX	
CODE IDENT. NO: 03554		DWG APPD: C. MICHLIK		SCALE: 1:1		PROJECT: SHEET 4 OF 4	
				OCT07/13		REV: H	

DO NOT SCALE DRAWING

THIS DOCUMENT CONTAINS PROPRIETARY INFORMATION AND SUCH INFORMATION MAY NOT BE DISCLOSED TO OTHERS FOR ANY PURPOSE OR USED FOR MANUFACTURING PURPOSES WITHOUT PERMISSION FROM AMPHENOL CANADA CORP.