

This document is the property of Amphenol Corporation and is delivered on the express condition that is not to be disclosed, reproduced or used, in whole or in part, for manufacture or sale by anyone other than Amphenol Corporation without its prior consent, and that no right is granted to disclose or to use any information in this document.

The marking on this product doesn't contain environmental hazardous material and must follow one or more specifications per Material Specification SS-00259 for Sony GP compliant or per directive 2011/65/EC for RoHS compliant or per IEC 61249-2-21 for Halogen Free compliant.

REVISIONS				
SYM	ECN No.	DESCRIPTION	DATE	BY
AX1		INITIAL REVISION	08/05/2016	Sondra Sang
AX2		MODIFIED TITLE	10/05/2016	Sondra Sang
AX3		MODIFIED DRAWING	11/16/2016	Sondra Sang
AX4		ADDED SHELL DIP LENGTH 1.6MM IN PNS	01/20/2017	Sondra Sang
AX5		ADDED SHELL PLATING OPTIONS	05/04/2017	Sondra Sang

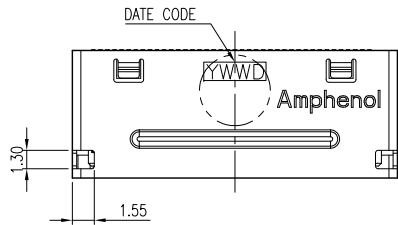

DATE CODE
Y WW D
1~7: DATE NO.
12: WEEK NO.
6: 2016

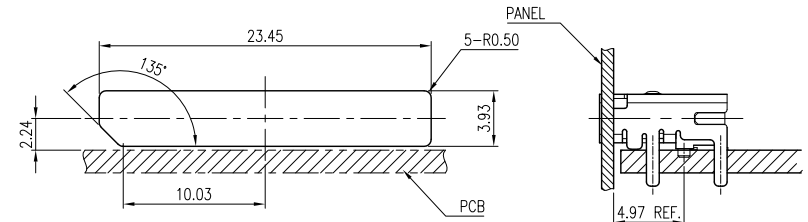
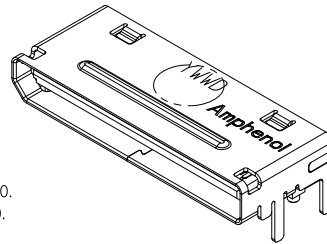

RECOMMENDED PANEL CUT-OUT

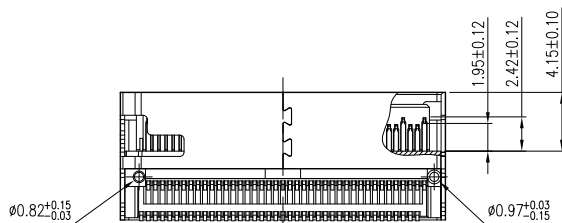
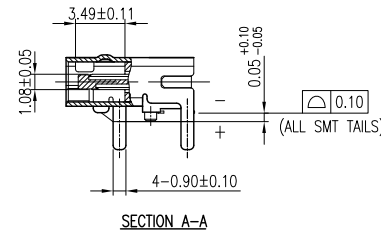
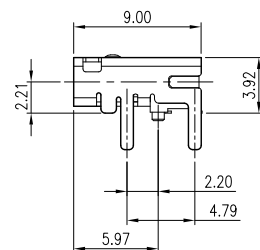
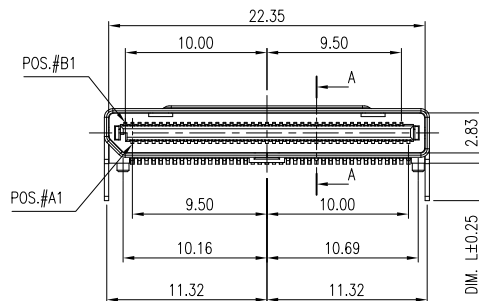

PART NUMBER:
G14B 801 X 1 X X X X HR

CONTACT FINISH
0: GOLD FLASH
1: 15μ" GOLD
2: 30μ" GOLD

SHELL PLATING OPTION
BLANK: ELECTROLESS NICKEL
1: MATTE TIN OVER NICKEL

PACKING METHOD
1: TRAY
2: TAPE & REEL (STANDARD)

SHELL OPTIONAL
5: DIP, DIM. L=2.1mm
6: DIP, DIM. L=2.9mm
7: DIP, DIM. L=3.7mm
8: DIP, DIM. L=1.6mm

INSULATOR OPTION
1: LCP, BLACK
3: LCP, BLUE
4: LCP, NATURAL WHITE

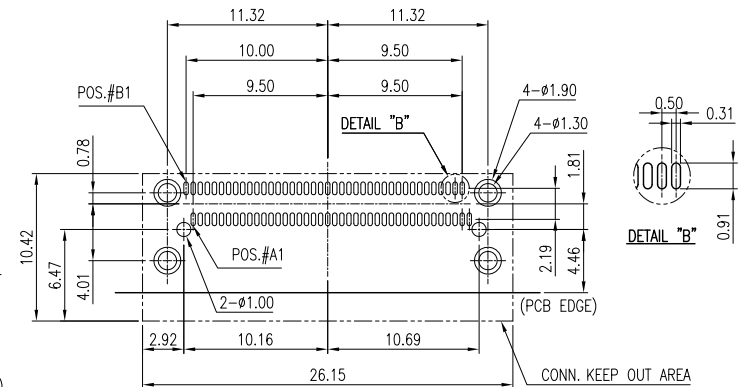

RECOMMENDED PCB LAYOUT- TOP VIEW
(GENERAL TOLERANCE: ±0.05)

NOTES:

- HOUSING: HIGH TEMP. THERMOPLASTIC, UL 94V-0, COLOR- OPTIONAL
- CONTACT: COPPER ALLOY, SELECTIVE. GOLD PLATED ON CONTACT AREA, 100μ" MATTE TIN PLATED ON SOLDERING TAIL, 50μ" MIN. NICKEL UNDER-PLATED OVERALL
- SHELL: STAINLESS STEEL, 50μ" MIN. ELECTROLESS NICKEL PLATED OVERALL OR 80μ"~120μ" MATTE TIN PLATED ON SOLDERING TAIL OVER 50μ" MIN. NICKEL PLATING OVERALL
- THIS PRODUCT DOESN'T CONTAIN ENVIRONMENTAL HAZARDOUS MATERIALS PER DIRECTIVE 2011/65/EC FOR RoHS AND PER IEC 61249-2-21 FOR HALOGEN FREE COMPLIANT.

TOLERANCE	APPROVALS	DATE	TITLE	Amphenol® Amphenol Corporation Amphenol Taiwan Corporation		
X. X.X ±0.30 X.XX ±0.20 X.XXX ±0.10	DRAWN Sondra Sang	05/04/2017	OCULINK 8X CONN. RECEPTACLE, R/A SHELL DIP, INTERNAL TYPE	PART No. G14B 801X 1XX XX HR		
	CHECKED Chenny Yeh	05/04/2017				
ANGULAR ±1°	APPROVED Hank Hsu	05/04/2017	UNIT mm SCALE NA	SIZE A3 SHEET 1 OF 1	REV. AX5	
UNLESS OTHERWISE SPECIFIED	DWG TYPE CUST DWG	PROJECT CODE TXXX				