

ROHS

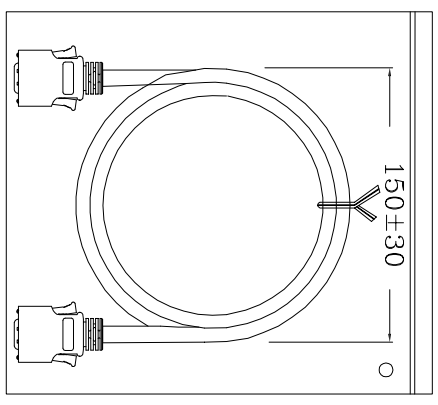
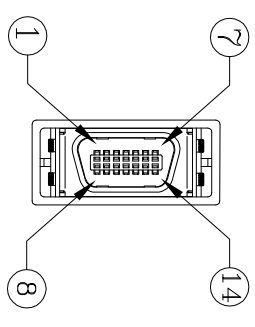
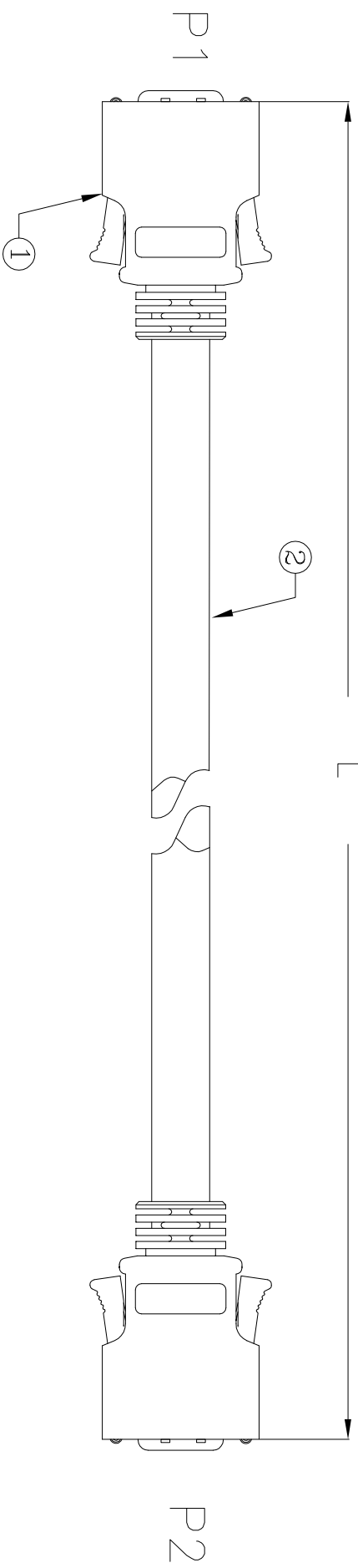

- NOTES:
1. ELECTRICAL TEST: 100% OPEN, SHORT & MISS WIRE TEST.
 2. CONDUCTOR RESISTANCE: 5 OHMS MAX.
 3. INSULATOR RESISTANCE: 1M OHMS MIN, DC 300V 0.01sec.
 4. THIS PRODUCT MEET ROHS STANDARD ENVIRONMENTAL PROTECTION POLICY.

PIN ASSIGNMENT

P1	SIGNAL	P2	P1	SIGNAL	P2
1	Y	1	8	SIGNAL	8
2	Y GND	2	9	SIGNAL	9
3	Pb	3	10	SIGNAL	10
4	Pb GND	4	11	SIGNAL	11
5	Pr	5	13	SIGNAL	13
6	Pr GND	6	12	SHORT	12
7	SIGNAL	7	14	SHORT	14

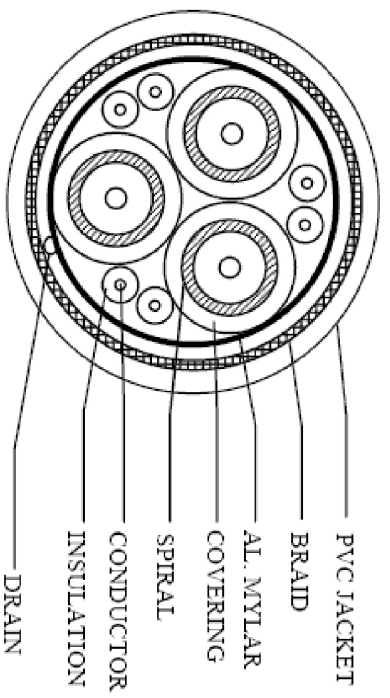

Port NO	LENGTH	REMARK
1	FC-DC14-01A L=1000MM	
2	FC-DC14-02A L=1500MM	
3	FC-DC14-03A L=3000MM	

QUALITY SYMBOLS	CRITICAL	MAJOR
□	☒	☒

ITEM	PART NAME	DESIGN	DRAWN	PART NO.	QTY
1	CONNECTOR	SCSI 14Pin Male ASSY		FC-DC14-XXA	2SET
2	CABLE	UL20276 30AWG*3COAX+28AWG*6C+AL+BRAID PVC JACKET COLOR:BLACK OD= 6.3mm		FC-DC14-XXA	1PCS

TOLERANCES	ANGLE: ±1°
±0.10	

DESCRIPTION	DRAWING NO.	REV
SCSI MDR-14P CABLE		C

REV	DESCRIPTION	DATE
A	圖面發行	2006-05-22

东莞市箐园电子有限公司

THIS DRAWING CONTAINS INFORMATION THAT IS PROPRIETARY TO KinKuo INCORPORATED AND SHOULD NOT BE USED WITHOUT WRITTEN REMISSION.