

REV.	DATE

RoHS

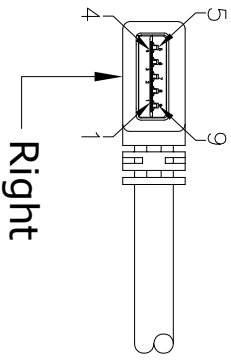
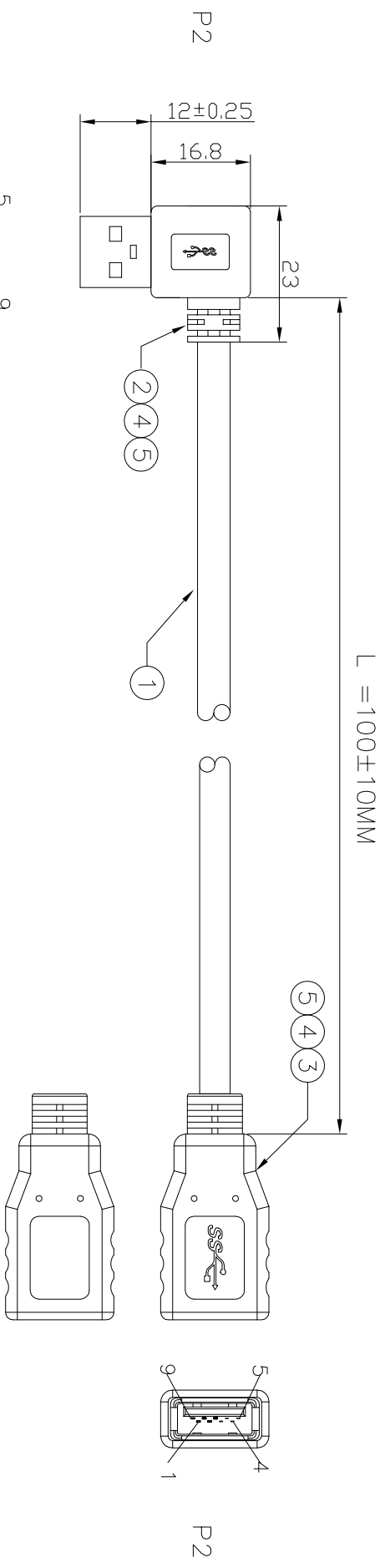

P1	PIN OUT	P2
1	RED	1
2	WHITE	2
3	GREEN	3
4	BLACK	4
5	BLUE	5
6	YELLOW	6
7	DRAIN	7
8	PURPLE	8
9	ORANGE	9
SHELL: DRAIN+BRAID		SHELL

- NOTE:**
1. 100% OPEN & SHORT WIRE TEST;
 2. CONTACT RESISTANCE 2ohm Max;
 3. INSULATION RESISTANCE 10M ohm Min;
 4. HI-POT DC 300V;

NO.	MATERIAL.P/N	DESCRIPTION	Q'TY	VENDOR	APPROVED:	DWG NO:	REV:	UNIT:	DATE:
5	PVC 45P		15G		<p style="text-align: center;">东莞市箐国电子有限公司</p> <p>UNLESS OTHERWISE SPECIFIED TOLERANCE: x.x ± ; angles: ° ;</p> <p>DESCRIPTION: USB 3.0 AM to USB 3.0 AF(全包)</p> <p>CUSTOMER P/N: LKU30AMF-R001</p> <p>PRODUCT NO.: 20200514-27</p> <p>SCALE: NONE</p>	20200514-27	X/0	mm	20.05.14
4	PE		4G						
3	USB(3.0) A TYPE Female		1SET						
2	USB(3.0) A TYPE Male		1SET						
1	UL20276 (USB3.0) (1P#28+AE)*2+2C#24+1P#28+AE(B(AL) OD:5.5MM BLACK L:xx MM		1PCS						

REV.		DATE
△		
△		

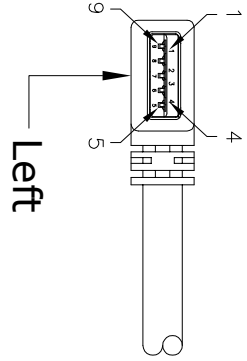
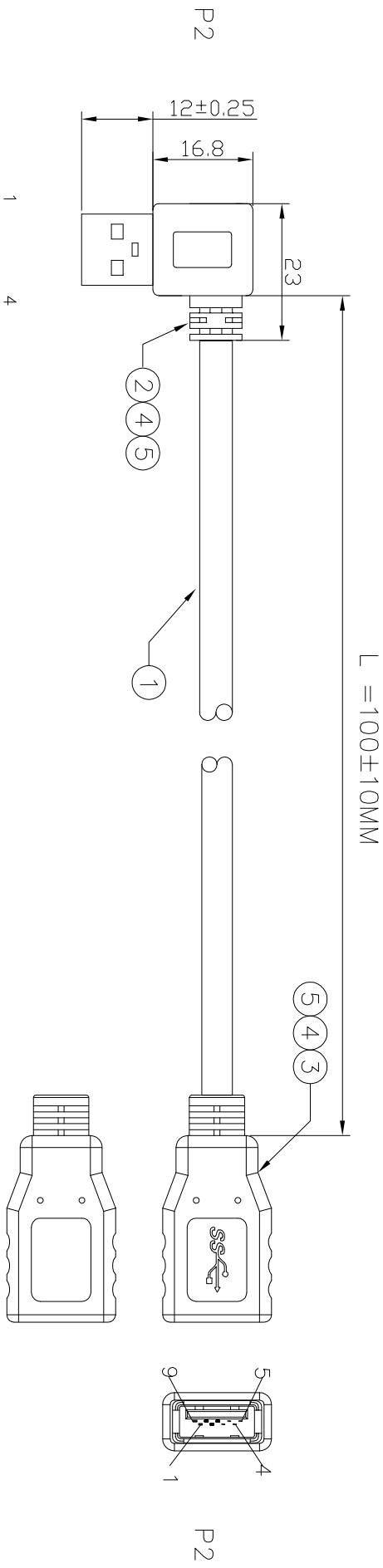

PIN	OUT
P1	P2
1	1
2	2
3	3
4	4
5	5
6	6
7	7
8	8
9	9
SHELL	SHELL

- NOTE:**
1. 100% OPEN & SHORT WIRE TEST;
 2. CONTACT RESISTANCE 2ohm Max;
 3. INSULATION RESISTANCE 10M ohm Min;
 4. HI-POT DC 300V;

5	PVC 45P	15G			<p>东莞市箐围电子有限公司</p> <p>UNLESS OTHERWISE SPECIFIED TOLERANCE : x.x ± ; angles ± ; DRAWN: ; CHECKED: ; APPROVED: ;</p> <p>DESCRIPTION: USB 3.0 AM to USB 3.0 AF(全包)</p> <p>CUSTOMER P/N: LKU30AMF-L001</p> <p>PRODUCT NO.: DWG NO: 20200514-27</p> <p>SCALE: NONE</p> <p>REV: X/0 UNIT: mm SHEET: 1 of 1</p>
4	PE	4G			
3	USB(3.0) A TYPE Female	1SET			
2	USB(3.0) A TYPE Male	1SET			
1	UL 20276 (USB3.0) (1P#28+AE)*2+2C#24+1P#28+AE(B(AL) OD:5.5MM BLACK L:xx MM	1PCS			
NO.	MATERIAL.P/N	Q'TY	VENDOR	DESCRIPTION	