

NOTE:  
 A: SPCC/Nickel  
 B: SPCC/Au

SECTION: A-A  
 SHELL Plating  
 Contact Plating  
 E: Au 5u  
 H: Au 15u  
 K: Au 30u

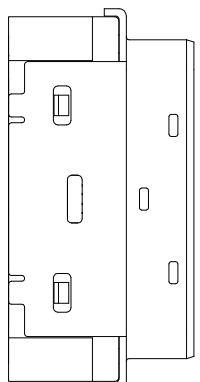

The view without cover-1 and cover-2

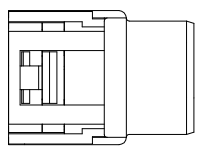
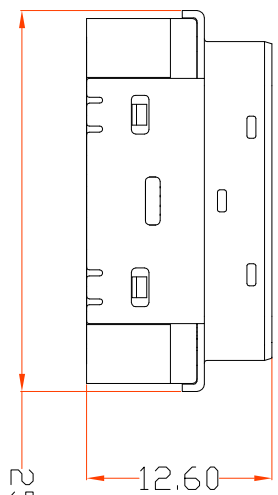
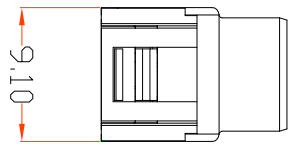
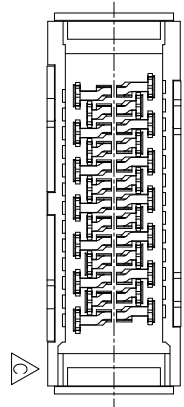

ROHS COMPLIANT

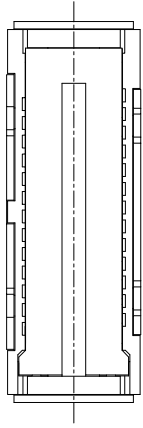

7	3M 磁珠	9495LE Adhesive transfer tape		
6	COVER-2	PBT-G.F30%UL94V-0	COLOUR: BLACK	
5	COVER-1	PBT-G.F30%UL94V-0	COLOUR: BLACK	
4	S-TERMINAL	Copper Alloy (T=0.30mm)	PLATING: SEE NOTE	
3	L-TERMINAL	Copper Alloy (T=0.30mm)	PLATING: SEE NOTE	
2	SHELL	SPCC (T=0.50mm)	PLATING: Nickel	
1	HOUSING	PBT-G.F30%UL94V-0	COLOUR: BLACK	

QUALITY SYMBOLS		Tolerance		NAME: SCS1 28P MALE IDC TYPE 主体 (3M 弹片式 同等品)		PART NO. AJ1XA026XM	
□ :	CRITICAL	x.	±0.50	REV: C	UNIT: mm	DRW BY: DRW NHU	CHK BY: KING ZHOU
⊘ :	MAJOR	x	±0.30	SCALE: NONE	DATE: 2010/07/16	APP BY:	DRAWING NO. AJ1XA-04
∇ :	ZERO DEFECT S.P.C	.xx	±0.30	<p>东 莞 市 箐 园 电 子 有 限 公 司</p>			
C 10-09-01 change 3M tape ,cover-01 and cover-02		JANECHEN		APPROVER		5	
B 10-08-03 New products number		JANECHEN		DESCRIPTION		7	
A 10-07-16 Issue		JANECHEN		DATE		8	

ROHS COMPLIANT

3M-TAPE

磨砂

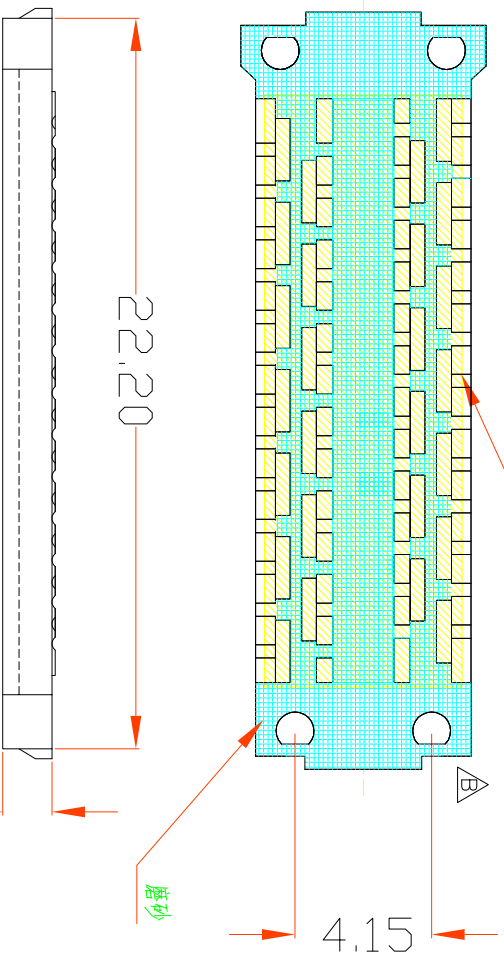
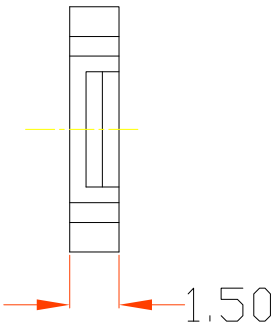

1.50

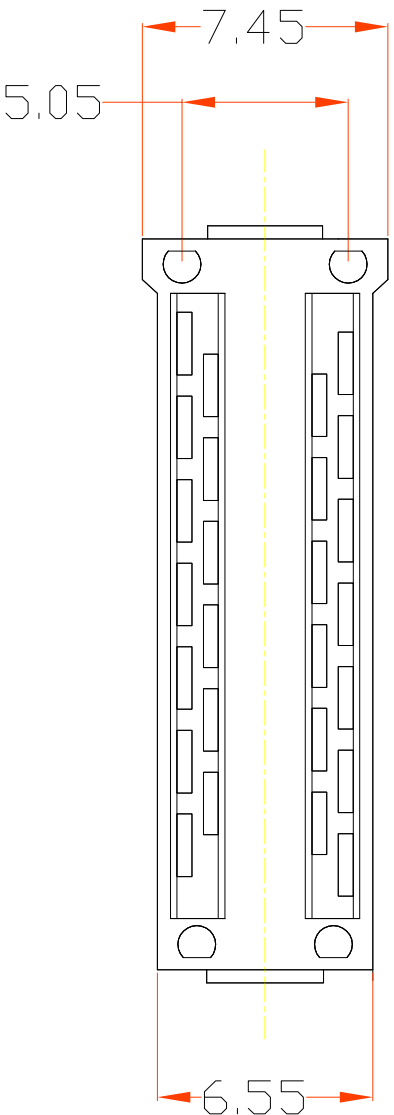
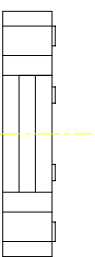

PART NO.:  
BJ1AA0260M

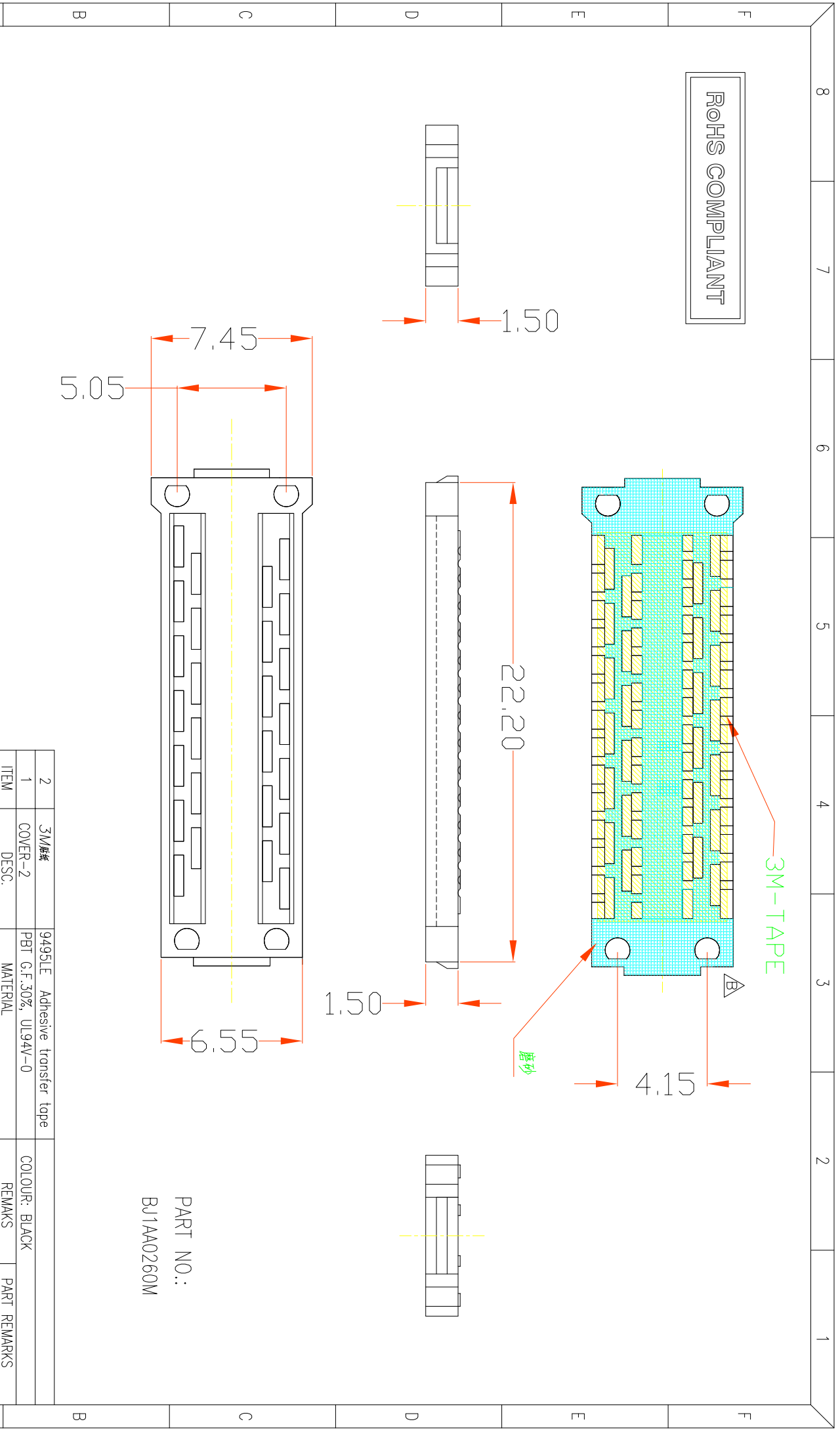

2	3M/康泰	9495LE Adhesive transfer tape	COLOUR: BLACK	PART REMARKS
1	COVER-2	PBT G.F.30%, UL94V-0		
ITEM	DESC.	MATERIAL	REMARKS	PART REMARKS

Tolerance		NAME:	SGST 26P/M PUNCTURE COVER-2	PART NO.	BJ1AA0260M
□ :	☒ :	REV:	(客户用图)	APP BY	DRAWING NO.
CRITICAL	MAJOR	A			BJ1XX-03
∇ :	∇ :	SCALE:	NONE	DATE:	2010/07/16
ZERO DEFECT	S.P.C	UNIT:	mm	DAW NHU	KING ZHOU

QUALITY SYMBOLS	QUALITY SYMBOLS	APPROVER	KINGZHOU
□ :	☒ :	DATE	10-07-16
CRITICAL	MAJOR	DESCRIPTION	图面发行
∇ :	∇ :	SIDE	8
ZERO DEFECT	S.P.C		

东 莞 市 箐 国 电 子 有 限 公 司		2		1	
-----------------------	--	---	--	---	--



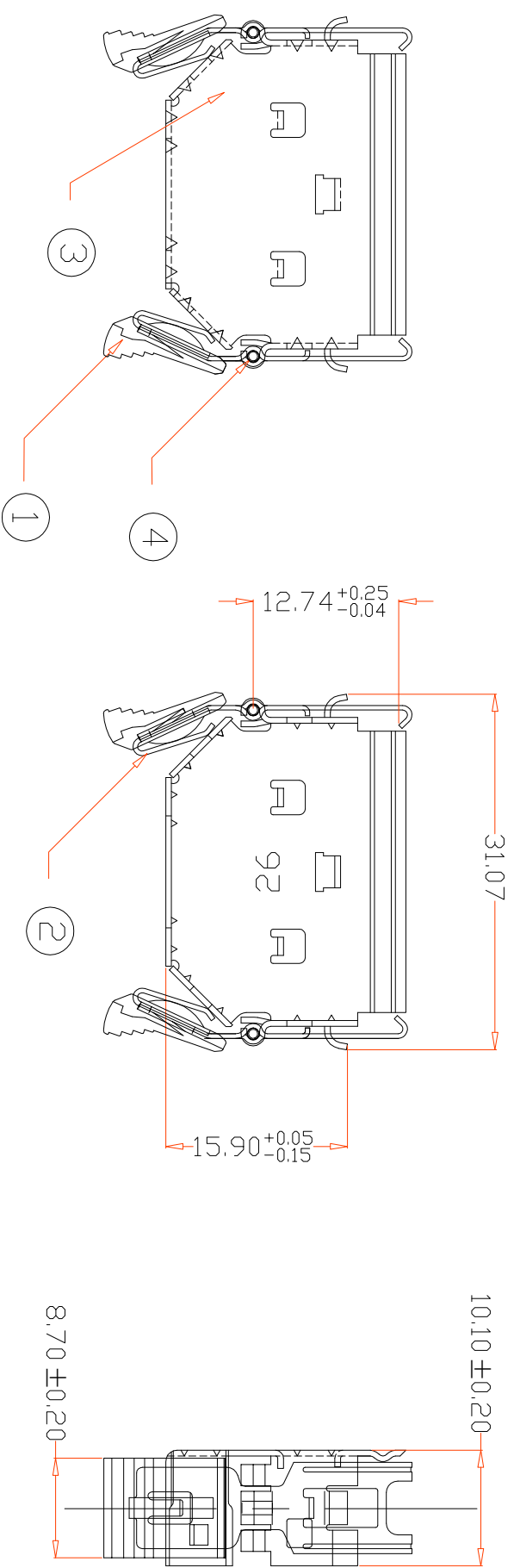

PART NO.:

BU1 X X 0260M

WRENCH HOUSING COLOR:

A: BLACK  
C: BEIJ

UPPER COER PLATING:

B: Nickel  
M: G/F

ROHS COMPLIANT

4	插销	SUS304-H T=0.10mm		
3	上铁壳	SPEC T=0.50mm	PLATING: Nicke 100u"	
2	扳手弹片	SUS301-1/2H T=0.40mm		
1	扳手塑胶	ABS ; COLOUR: BEIGE		

QUALITY SYMBOLS

Tolerance

NAME: SCST 26P MATE 柳合上盖+鱼钩型扳手弹片 (客户用图)  
REV: A  
SCALE: NONE  
DATE: 2010/07/16  
UNIT: mm  
DRW BY: DAW NHU  
CHK BY: KING ZHOU  
PART NO.: BU1XX0260M  
APP BY: KINGZHOU  
DRAWING NO.: BU1XX-02

CRITICAL MAJOR

Zero Defect S.P.C

REMARKS

10-07-16 图面发行  
KINGZHOU

APPROVER

DATE

DESCRIPTION

8	7	6	5	4	3	2	1
---	---	---	---	---	---	---	---

东莞市箐国电子有限公司

ROHS COMPLIANT

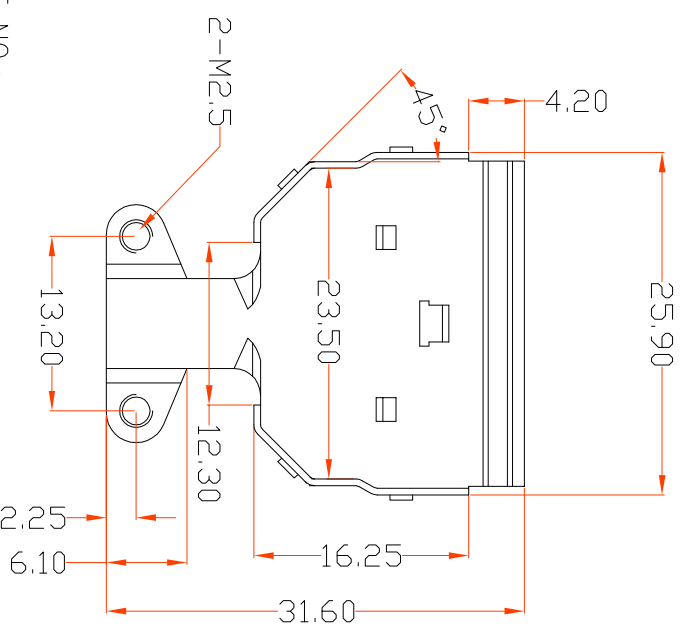
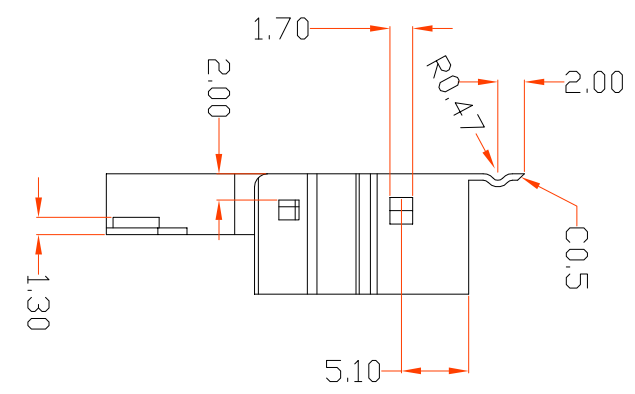
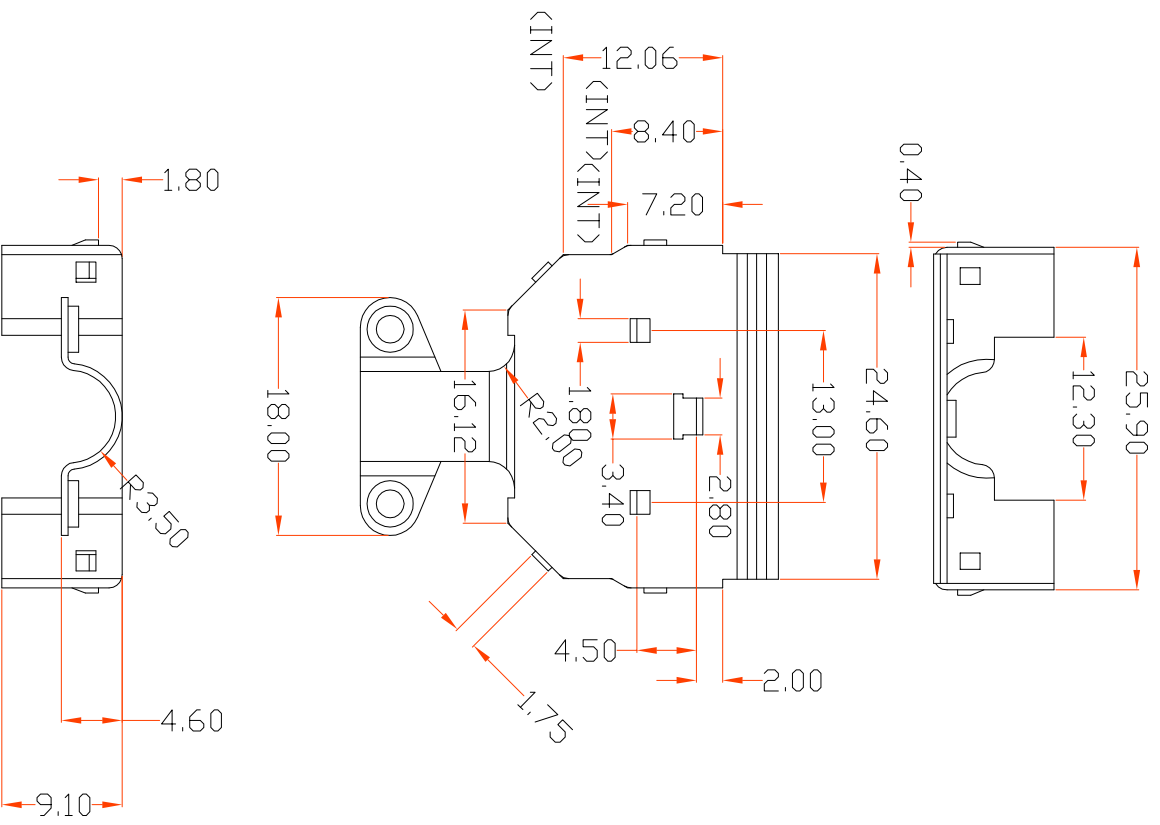

• PART NO.:

SJ1S2026XM

LOWER COVER PLATING  
B:NI 80u"

ITEM	DESC.	MATERIAL	REMARKS	PART REMARKS
1	LOWER COVER	STEEL (T=0.50mm)	PLATING: SEE NOTE	

QUALITY SYMBOLS	Tolerance	NAME:	SCSI 26P MALE 铆合下盖 (3M 弹片式同等品)		PART NO.	SJ1S2026XM
-----------------	-----------	-------	--------------------------------	--	----------	------------

CRITICAL	MAJOR	REVISION	UNIT:	DRW BY:	CHK BY:	APP BY:	DRAWING NO.
□	⊠	x	mm	A	DAW NHU	KING ZHOU	AJ126-04

ZERO DEFECT	S.P.C	SCALE:	DATE:	DATE:	DATE:
▽	▽	NONE	2010/07/16	DAW NHU	KING ZHOU

APPROVER	APPROVER	DATE	DATE
KINGZHOU	KINGZHOU	10-07-16	10-07-16

DESCRIPTION	DESCRIPTION	DATE	DATE
图面发行	图面发行	10-07-16	10-07-16

东莞市箐国电子有限公司

ROHS COMPLIANT

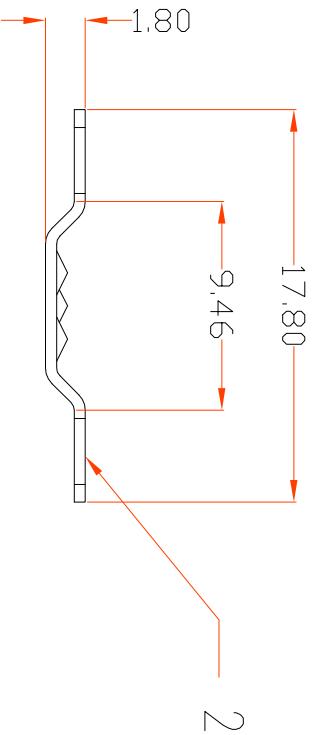
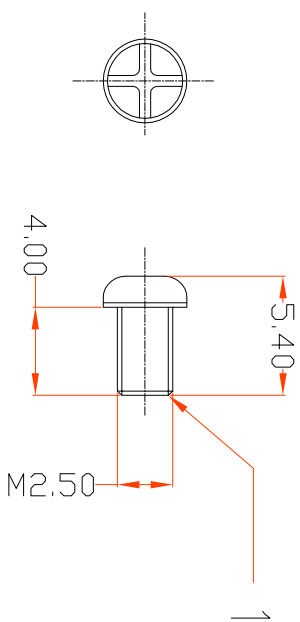
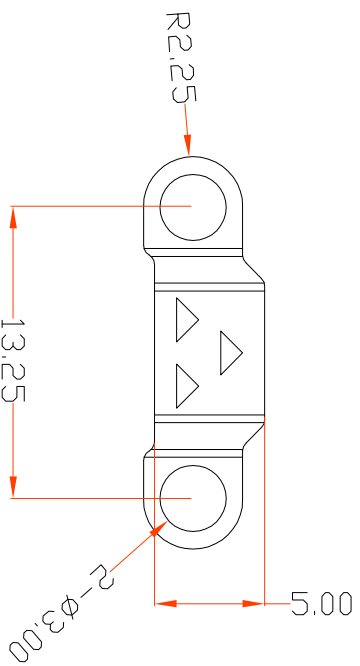

PART NO.:  
SJ1S40260M

PART NO.:  
SJ1S30260M

ITEM	DESC.	MATERIAL	REMARKS	PART REMARKS
2	线扣	SUS304-1/2H T=0.50mm		
1	螺丝	Fe		

QUALITY SYMBOLS

□ :  
CRITICAL

☒ :  
MAJOR

▽ :  
ZERO DEFECT

Tolerance

X.  
±0.50

.X  
±0.30

.XX  
±0.30

NAME:

REV:

SCALE:

NONE

DATE:

UNIT:

DATE:

DATE:

mm

DRW BY

CHK BY

KING ZHOU

DAW NHU

PART NO.

SJ1S30260M/SJ1S40260M

APP BY

REMARKS

SCST 26P MATE 线扣+螺丝 (3M 弹片式同等品)  
(客户用图)

DATE:

DATE:

REMARKS

DATE:

DATE:

DATE:

DATE:

DATE:

DATE:

DATE:

DATE:

DATE:

DATE:

DATE:

DATE:

DATE:

DATE:

DATE:

DATE:

DATE:

DATE:

DATE:

DATE:

DATE:

DATE:

DATE:

东莞市箐国电子有限公司

APPROVER

KINGZHOU

DESCRIPTION

图面发行

DATE

10-07-16

SIDE

△

8

7

6

5

4

3

2

1

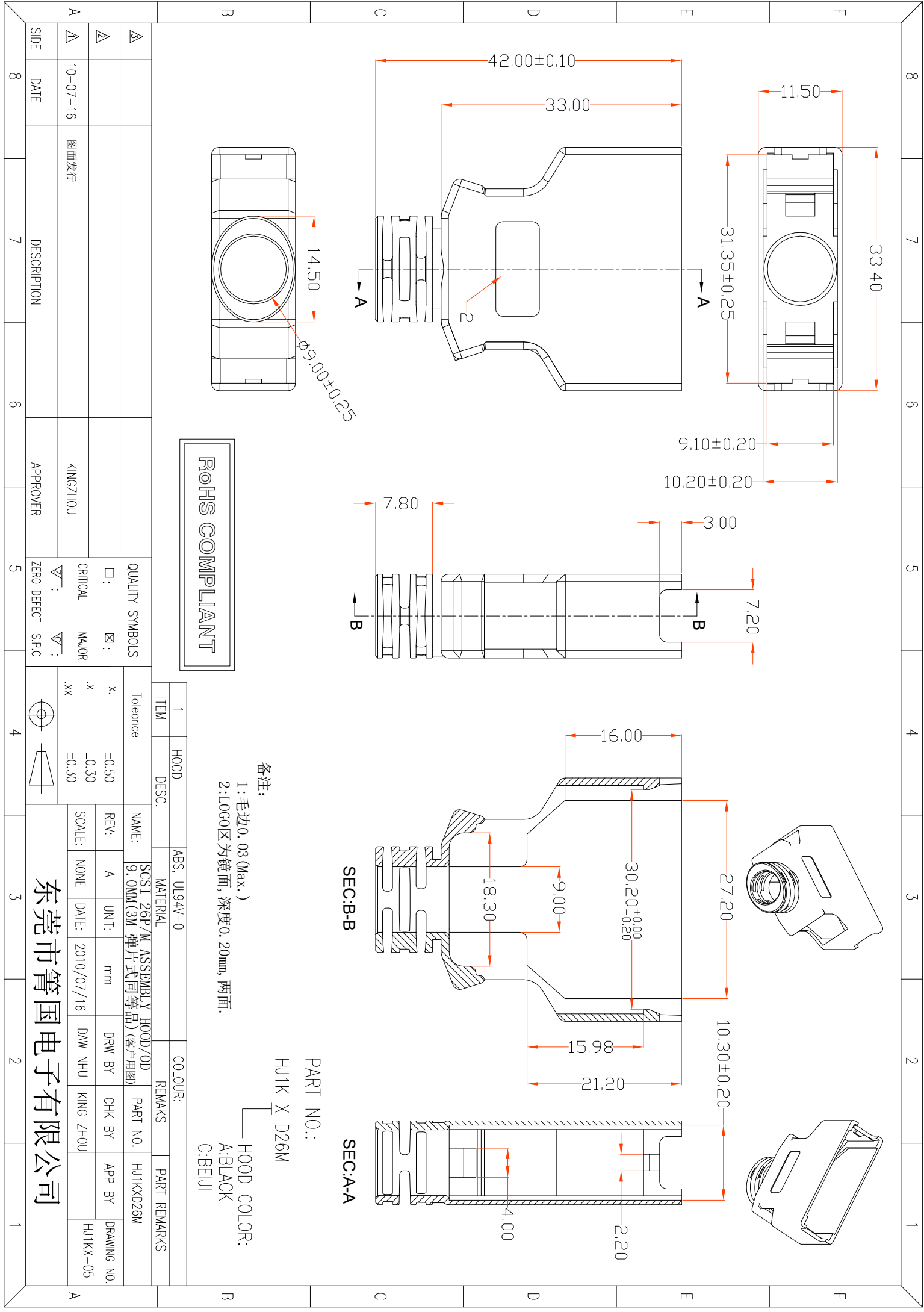

**ROHS COMPLIANT**

备注:  
 1:毛边0.03 (Max.)  
 2:LOGO区为镜面, 深度0.20mm, 两面.

PART NO.: HJ1K X D26M  
 HOOD COLOR: A:BLACK C:BEIJ

1	HOOD	DESC:	ABS, UL94V-0	COLOR:		REMARKS	PART REMARKS
ITEM	DESC:	MATERIAL	ABS, UL94V-0	COLOR:		REMARKS	PART REMARKS
Tolerance		NAME:	SCST 26P/M ASSEMBLY HOOD/OD	PART NO.:	HJ1KXD26M	PART REMARKS	
x:	±0.50	REV:	A	UNIT:	mm	DRW BY:	CHK BY:
x:	±0.30	SCALE:	NONE	DATE:	2010/07/16	DAW NHU	KING ZHOU
.xx	±0.30						
QUALITY SYMBOLS		CRITICAL		MAJOR		DRAWING NO.:	
ZERO DEFECT		S.P.C				HJ1KX-05	

东莞市箐国电子有限公司

A	DATE	DESCRIPTION	APPROVER
8	10-07-16	图面发行	KINGZHOU

8	7	6	5	4	3	2	1
---	---	---	---	---	---	---	---