

No. of Contact	A ±0.25	B ±0.13	C ±0.38	D ±0.25
09	16.92	24.99	30.81	39.6
15	25.25	33.32	39.14	48
25	38.96	47.04	53.04	61.6
37	55.42	63.50	69.32	78

MATERIALS AND FINISH

SHELL : STEEL MATERIAL, FRONT NICKEL FINISHED
 BACK SHELL TIN FINISHED
 INSULATOR : PBT THERMOPLASTIC, 30% GLASS
 FILLED, UL 94V-0 RATED,
 CONTACT MATERIAL : BRASS
 CONTACT FINISH : FULL GOLD FINISHED
 WITH #4-40 THREADED RIVETS
 Protection grade ; Ingress Protection ;
 Environmental IP67

ELECTRICAL CHARACTERISTICS

CONTACT CURRENT RATING : 5.0 AMPS
 CONTACT RESISTANCE : 30 MILLIOHMS MAX.
 DIELECTRIC WITHSTANDING VOLTAGE : 1000 V AC MIN.
 INSULATION RESISTANCE : 5000 MEGAOHMS MIN.
 TEMPERATURE RATING : -55°C ~ +105°C
 GRADE:IP67

PART NO:

BA5-0XX311AN-01

No. of Contact:

09: 9Pin
 15: 15Pin
 25: 25Pin
 37: 37Pin

东莞市箜国电子有限公司

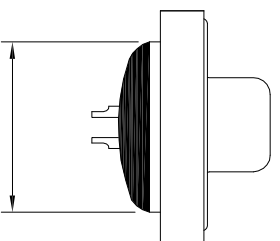
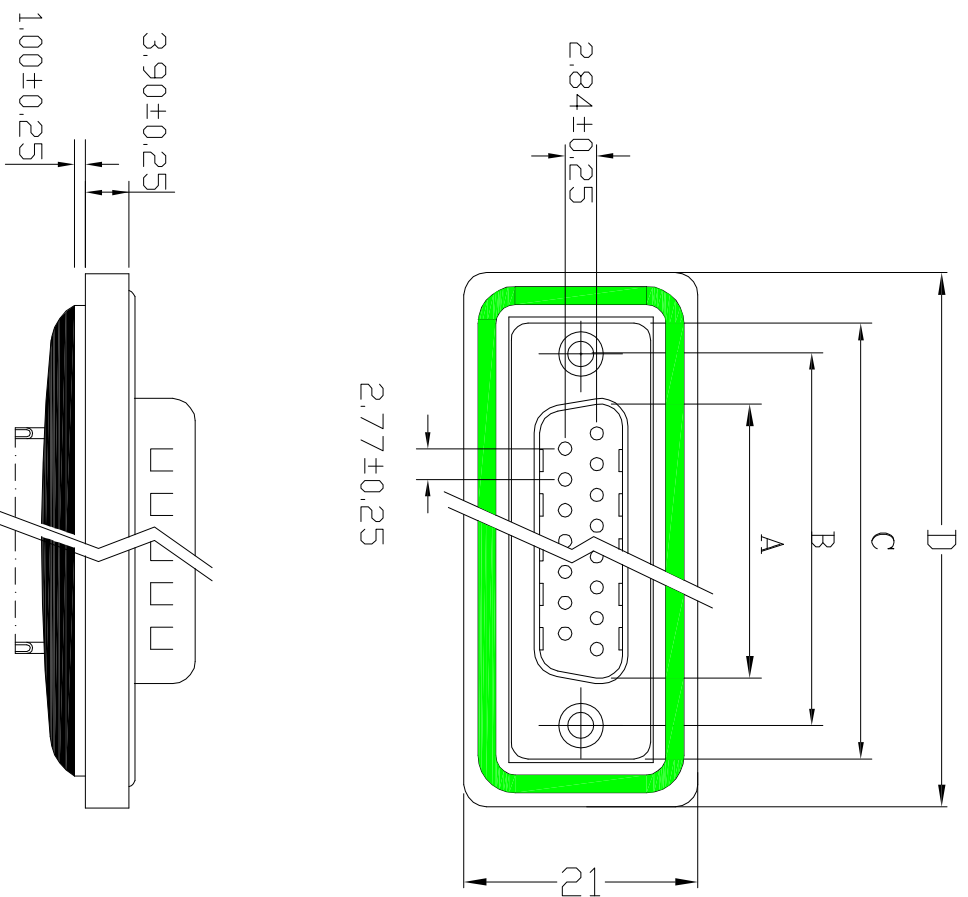

15.30±0.25

QUALITY SYMBOLS

□ : MAJOR

△ : CRITICAL

▽ : ZERO DEFECT

Tolerance

±0.50

±0.30

±0.25

NAME:

D-Sub Male Machine Pin, Solder Type (IP67 waterproof)

PART NO.

BA5-0XX311AN-01

REV:

A

UNIT:

mm

DRW BY

CHK BY

APP BY

DRAWING NO.

SCALE:

N:1

DATE:

2021/09/07

DAMN HU

KING ZHOU

APP BY

PD-DB01

东莞市箜国电子有限公司

DATE	DESCRIPTION	APPROVER
2021/09/07	新版发行	King Zhou

SIDE	DATE	DESCRIPTION	APPROVER
8			
7			
6			
5			
4			
3			
2			
1			