

This document is the property of Amphenol Corporation and is delivered on the express condition that it is not to be disclosed, reproduced or used, in whole or in part, for manufacture or sale by anyone other than Amphenol Corporation without its prior consent, & that no right is granted to disclose or to use any information in this document.

CUSTOMER DRAWING

REVISIONS

SYM	ECN	DESCRIPTION	DATE	APPROVED
1	N/A	FIRST RELEASE	12/06'17	IP
2	N/A	ADDING THE PACKAGE SPEC	4/13'18	IP
3	N/A	MODIFIED PART NUMBER CODING AND CHANGE COVER STRUCTURE	4/26'18	IP
4	N/A	ADDING CARRIER DIMENSION	5/9'18	IP
5	N/A	ADDING SHELL DIMENSION	5/21'18	IP
6	N/A	ADDING PCB HATCH DENOTE TRACE KEEP OUT AREA	7/16'18	IP
7	N/A	CHANGING THE PACKING CARRIER	8/13'18	IP
8	N/A	CHANGING THE PACKING CARRIER WIDTH	8/21'18	IP
9	N/A	ADDING TWO CIRCULAR HOLES ON THE COVER SURFACE TO DISTINGUISH THE DIRECTION AND ADDING HOUSING COLOR DESCRIPTION	11/14'18	IP

Part with Cap

Pick-Up Area

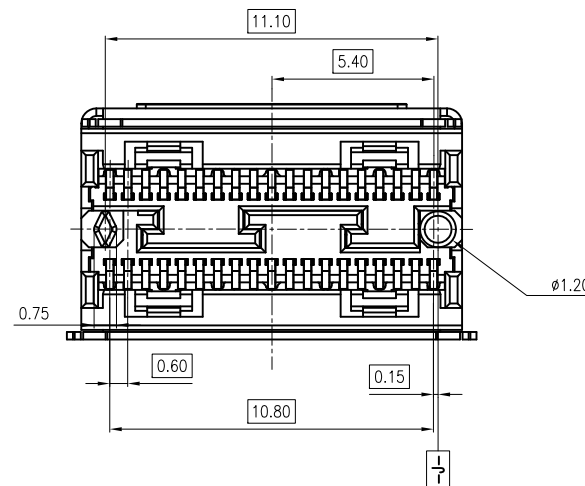
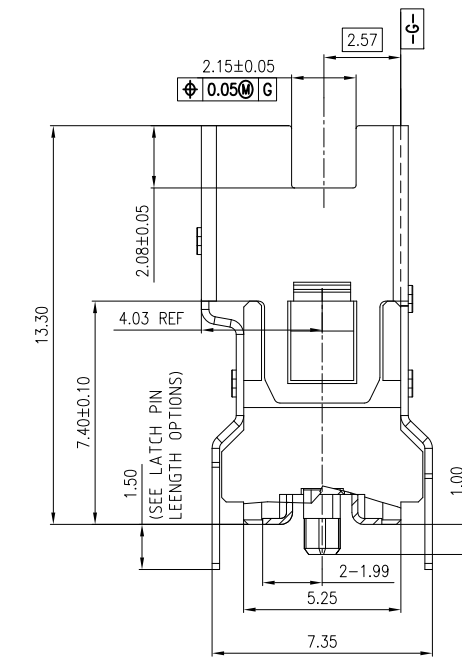
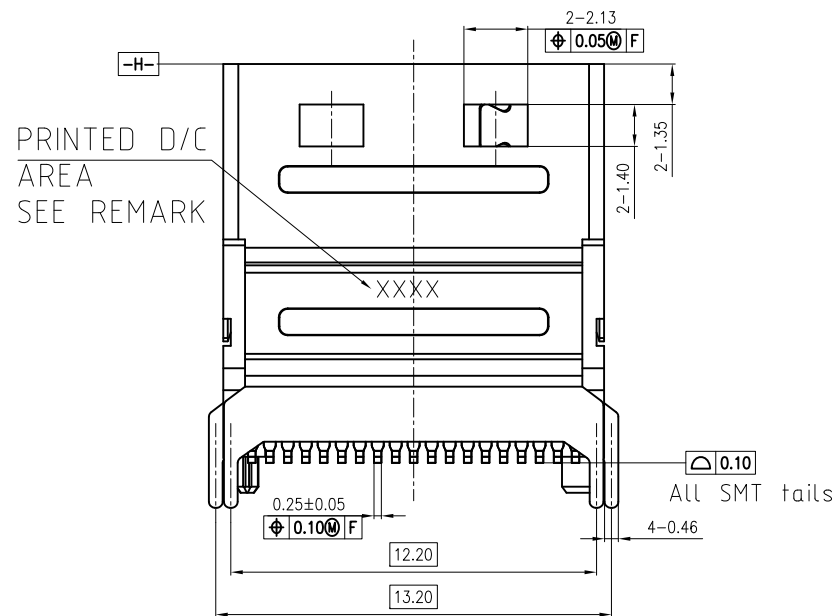
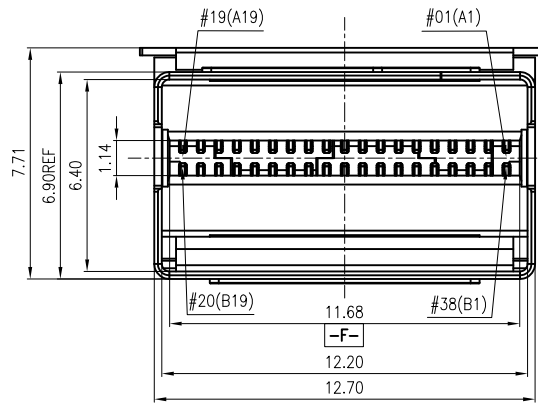
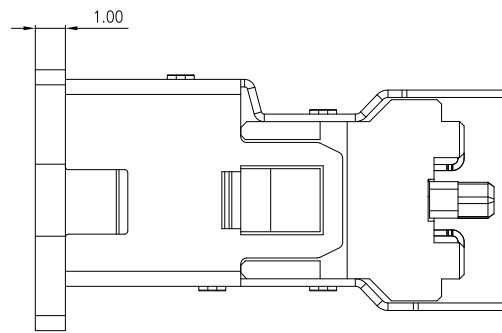
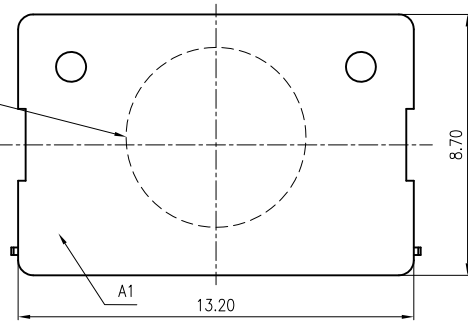

Remark:
 PRINTED D/C AREA
 印刷日期代码区域
 YYWW
 WEEK(周)
 YEAR(年)



UNLESS OTHERWISE SPECIFIED TOLERANCES	
U.S.	METRIC
.X	+/- 0.50
.XX	+/- 0.25
.XXX	+/- 0.20
FRACTIONS	+/-
ANGLES	+/- 3°

APPROVAL		DATE
DRAWN	Mike	11/14'18
CHECKED		
CHECKED		
DRAWING FILE : DRAWING\U10\U10DH38X2X02X-9		
ANGLE OF PROJECTION		

Amphenol		Amphenol East Asia Limited	
TITLE CUSTOMER DRAWING FOR SLIMLINE SAS X4 VERTICAL			
SIZE	DRAWING NO.	REV.	
A3	U10DH38X2X02X	9	
SCALE	NONE	SHEET 1 OF 2	

This document is the property of Amphenol Corporation and is delivered on the express condition that it is not to be disclosed, reproduced or used, in whole or in part, for manufacture or sale by anyone other than Amphenol Corporation without its prior consent, & that no right is granted to disclose or to use any information in this document.

CUSTOMER DRAWING

REVISIONS				
SYM	ECN	DESCRIPTION	DATE	APPROVED
		SEE SHEET 1		

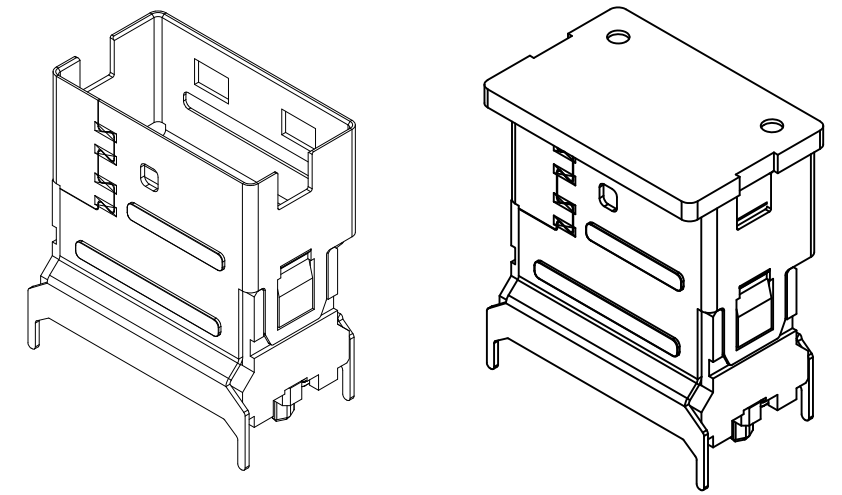
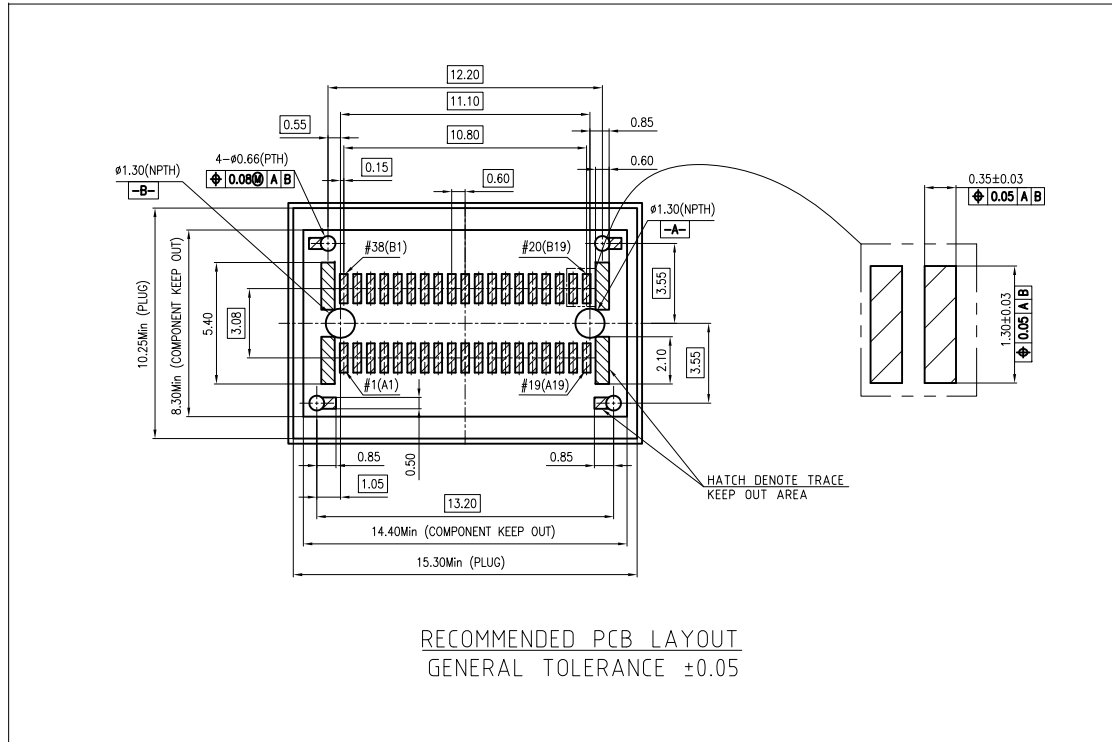

NOTES:

- MATERIAL:
HOUSING : SOLDER REFLOW PROCESS COMPATIBLE LCP, BLACK, UL94V-0
CONTACTS : HIGH PERFORMANCE COPPER ALLOY, PLATING REFER TO P/N SYSTEM
LATCH : STAINLESS STEEL, SOLDERABLE NICKEL OVER ALL
- RoHS COMPLIANT
- ORDER P/N SYSTEM:
U10DH38XXX02X

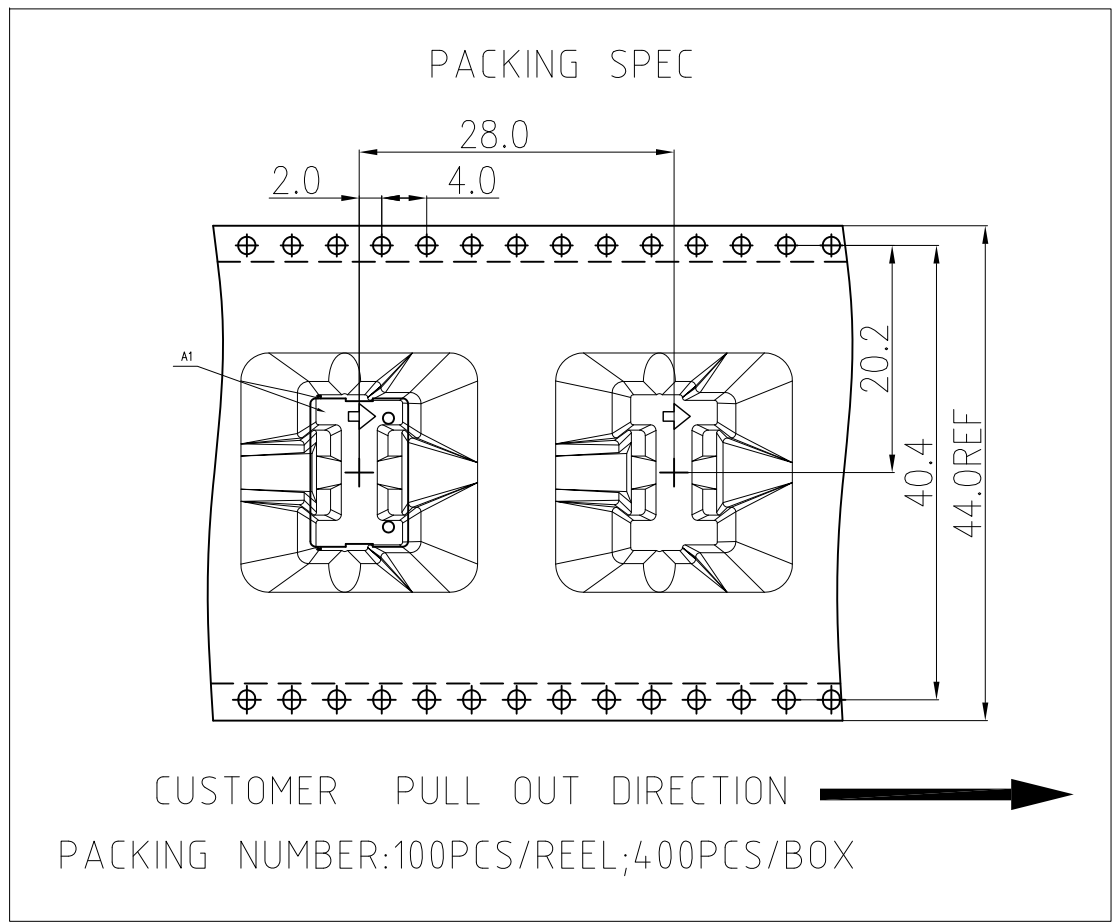

- Packing Options
T: tape&reel
- Options (resonance damping and latch options)
0: With resonance damping
1: No resonance damping
- LATCH PIN LENGTH OPTIONS
2: 1.50
4: 2.20
5: 3.00
6: 4.20
- CONTACT PLATING OPTION
2: 30 MICROINCHES OF GOLD ON MATING END WITH MATTE TIN ON SOLDER TERMINATION, NICKEL UNDERPLATE ALL OVER
3: 15 MICROINCHES OF GOLD ON MATING END WITH MATTE TIN ON SOLDER TERMINATION, NICKEL UNDERPLATE ALL OVER



UNLESS OTHERWISE SPECIFIED TOLERANCES	U.S.	METRIC	APPROVAL	DATE	Amphenol Amphenol East Asia Limited
	.X	+/-	0.50	Mike	
	.XX	+/-	0.25	CHECKED	TITLE CUSTOMER DRAWING FOR SLIMLINE SAS X4 VERTICAL
	.XXX	+/-	0.20	CHECKED	
	FRACTIONS	+/-		DRAWING FILE :	SIZE DRAWING NO. A3 U10DH38X2X02X
	ANGLES	+/-	3°	DRAWING\U10\U10DH38X2X02X-9	
FOR MATERIALS AND FINISHES SEE NOTES	REMOVE SHARP EDGES	ANGLE OF PROJECTION			
DIMENSIONS	U.S. INCHES				
(METRIC) (MM)			SCALE	NONE	REV. 9
			SHEET	2 OF 2	