

This document is the property of Amphenol Corporation and is delivered on the express condition that is not to be disclosed, reproduced or used, in whole or in part, for manufacture or sale by anyone other than Amphenol Corporation without its prior consent, and that no right is granted to disclose or to use any information in this document.

The marking on this product doesn't contain environmental hazardous materials per Material Specification SS-00259 for Sony GP compliant or per directive 2011/65/EU for RoHS compliant or per IEC 61249-2-21 for Halogen-Free compliant.

REVISIONS				
SYM	ECN No.	DESCRIPTION	DATE	APPROVED
AX1	NA	UNRELEASED REVISION	08/12/2013	HANK HSU
AX2	NA	DESIGN CHANGE	09/06/2013	HANK HSU
AX3	NA	ADDED 3.05 MIN. BOTTOM HEIGHT DIMENSION	09/13/2013	HANK HSU

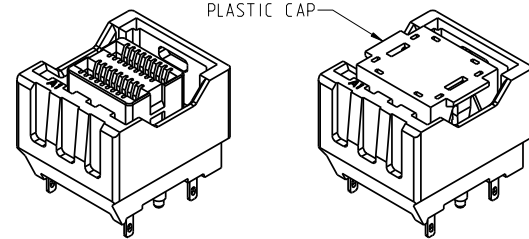
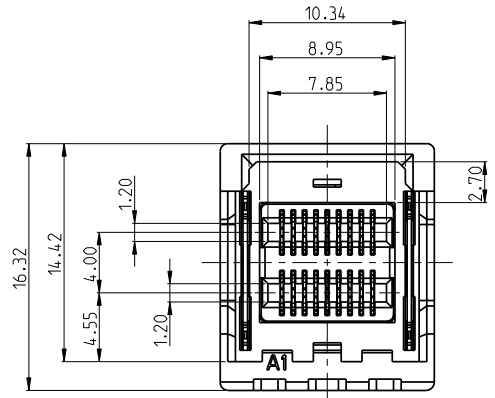

TABLE 1

DIM A	APPLICABLE PCB THK
2.40	1.57~1.60
3.59	2.36~2.79
3.98	3.18

PART NUMBER SYSTEM

G40H 4 X X X X X XX - X

Mini SAS HD Integrated Connector

Connector Style
4: V/T, w/enclosing wall

Number of Integration
X: OPTION
1: 1X1
2: 1X2

Contact Finish
X: OPTION
3: 30u" Gold

Terminal Style
X: OPTION
2: SMT, 100u" MIN MATTE TIN PLATING

Verification Code
X: OPTION
BLANK: STANDARD

Compliant Code
XX: OPTION
HR: Halogen-Free & RoHS

BOARDLOCK CODE
X: OPTION
1: 2.40 mm
2: 3.59 mm
3: 3.98 mm

Variation Code
X: OPTION
1: with Cap
2: without Cap

Packing Code
X: OPTION
1: Tray
2: Tape & Reel

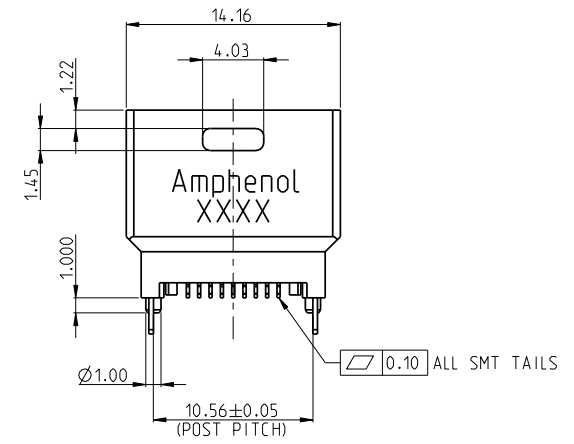
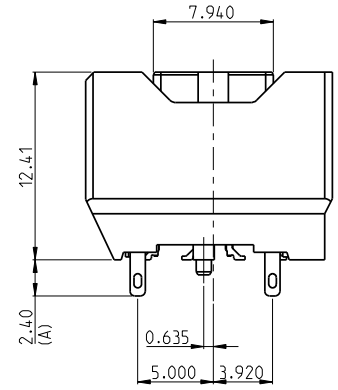
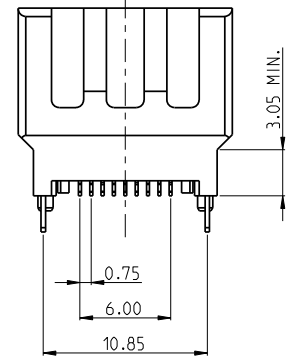

- NOTES:
- INSULATOR: HIGH TEMPERATURE UL94V-0, COLOR: BLACK
 - TERMINAL: COPPER ALLOYBRASS
CONTACT AREA: OPTION
SOLDERING AREA: OPTION
UNDER PLTING.: Ni 100u" MIN.
 - THIS PRODUCT DOESN'T CONTAIN ENVIRONMENTAL HAZARDOUS PER DIRECTIVE 2011/65/EU FOR RoHS AND PER IEC 61249-2-21 FOR HALOGEN-FREE COMPLIANT.

TOLERANCE	DRAWN	APPROVALS	DATE	TITLE	UNIT	SIZE	PART No.
X. X.X ±0.30 X.XX ±0.20 X.XXX ±0.10	DESIGNED	Hank Hsu	09/13/2013	MINI SAS HD INTEGRATED CONNECTOR 0.75 PITCH, V/T, SMT TYPE	mm	A3	G40H4XXXXXXHR
	CHECKED	Sondra Sang	09/13/2013				
	APPROVED	Hank Hsu	09/13/2013				
ANGULAR ±2°	DWG TYPE	CUST DWG	PROJECT CODE T515	UNIT SCALE	mm NA	SHEET 1 OF 3	REV. AX3
UNLESS OTHERWISE SPECIFIED							DWG No. G40H4XXXXXXHR

Amphenol®
Amphenol Corporation
Amphenol Taiwan Corporation

This document is the property of Amphenol Corporation and is delivered on the express condition that it is not to be disclosed, reproduced or used, in whole or in part, for manufacture or sale by anyone other than Amphenol Corporation without its prior consent, and that no right is granted to disclose or to use any information in this document.

The marking on this product doesn't contain environmental hazardous materials per Material Specification SS-00259 for Sony Gf compliant or per directive 2011/65/EU for RoHS compliant or per IEC 61249-2-21 for Halogen-Free compliant.

REVISIONS				
SYM	ECN No.	DESCRIPTION	DATE	APPROVED
AX1	NA	UNRELEASED REVISION	08/12/2013	HANK HSU
AX2	NA	DESIGN CHANGE	09/06/2013	HANK HSU
AX3	NA	ADDED 3.05 MIN. BOTTOM HEIGHT DIMENSION	09/13/2013	HANK HSU

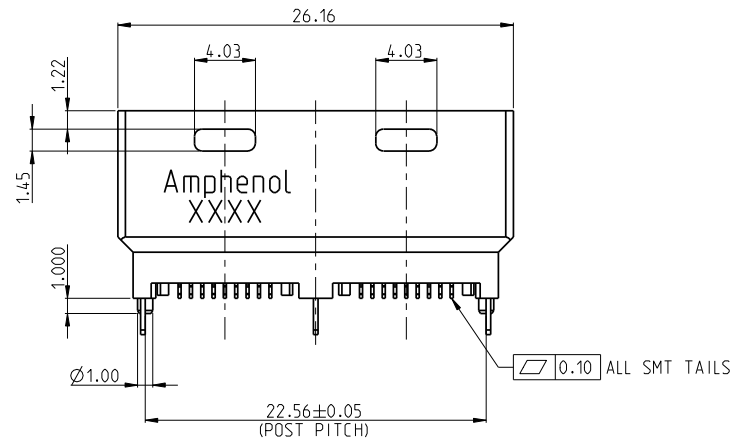
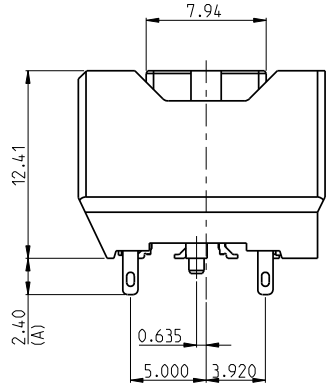
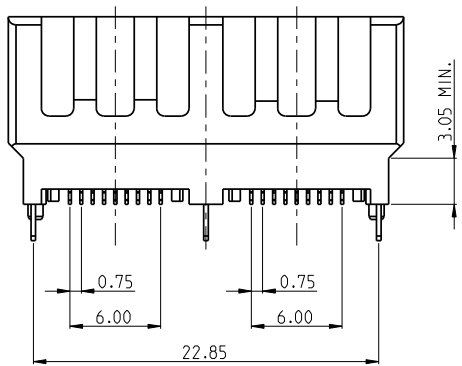
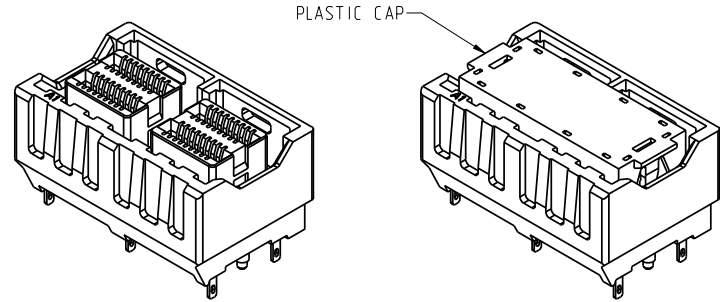
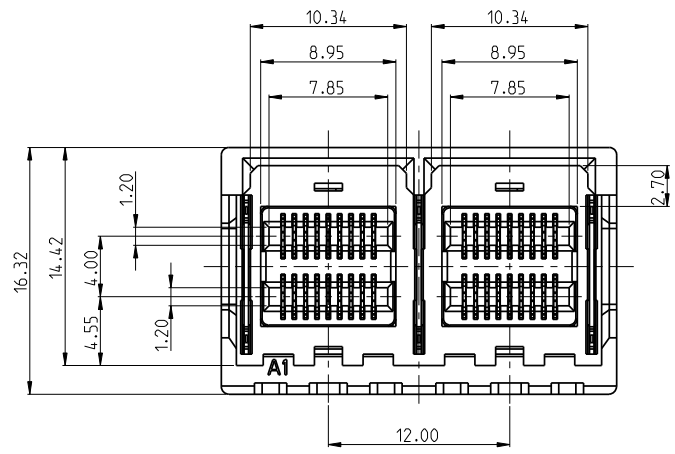

TOLERANCE	DRAWN	APPROVALS	DATE	TITLE	Amphenol® Amphenol Corporation Amphenol Taiwan Corporation			
X.		DESIGNED	09/13/2013	MINI SAS HD INTEGRATED CONNECTOR 0.75 PITCH, V/T, SMT TYPE	UNIT	SIZE	PART No.	G40H4XXXXXXHR
X.X	±0.30	CHECKED	09/13/2013		SCALE	SHEET	DWG No.	
X.XX	±0.20	APPROVED	09/13/2013		NA	2 OF 3	G40H4XXXXXXHR	
X.XXX	±0.10						REV.	AX3
ANGULAR	±2°	DWG TYPE	PROJECT CODE					
UNLESS OTHERWISE SPECIFIED		CUST DWG	T515					

This document is the property of Amphenol Corporation and is delivered on the express condition that is not to be disclosed, reproduced or used, in whole or in part, for manufacture or sale by anyone other than Amphenol Corporation without its prior consent, and that no right is granted to disclose or to use any information in this document.

The marking on this product doesn't contain environmental hazardous materials per Material Specification SS-00259 for Sony Gb compliant or per directive 2011/65/EU for RoHS compliant or per IEC 61249-2-21 for Halogen-Free compliant.

REVISIONS				
SYM	ECN No.	DESCRIPTION	DATE	APPROVED
AX1	NA	UNRELEASED REVISION	08/12/2013	HANK HSU
AX2	NA	DESIGN CHANGE	09/06/2013	HANK HSU
AX3	NA	ADDED 3.05 MIN. BOTTOM HEIGHT DIMENSION	09/13/2013	HANK HSU

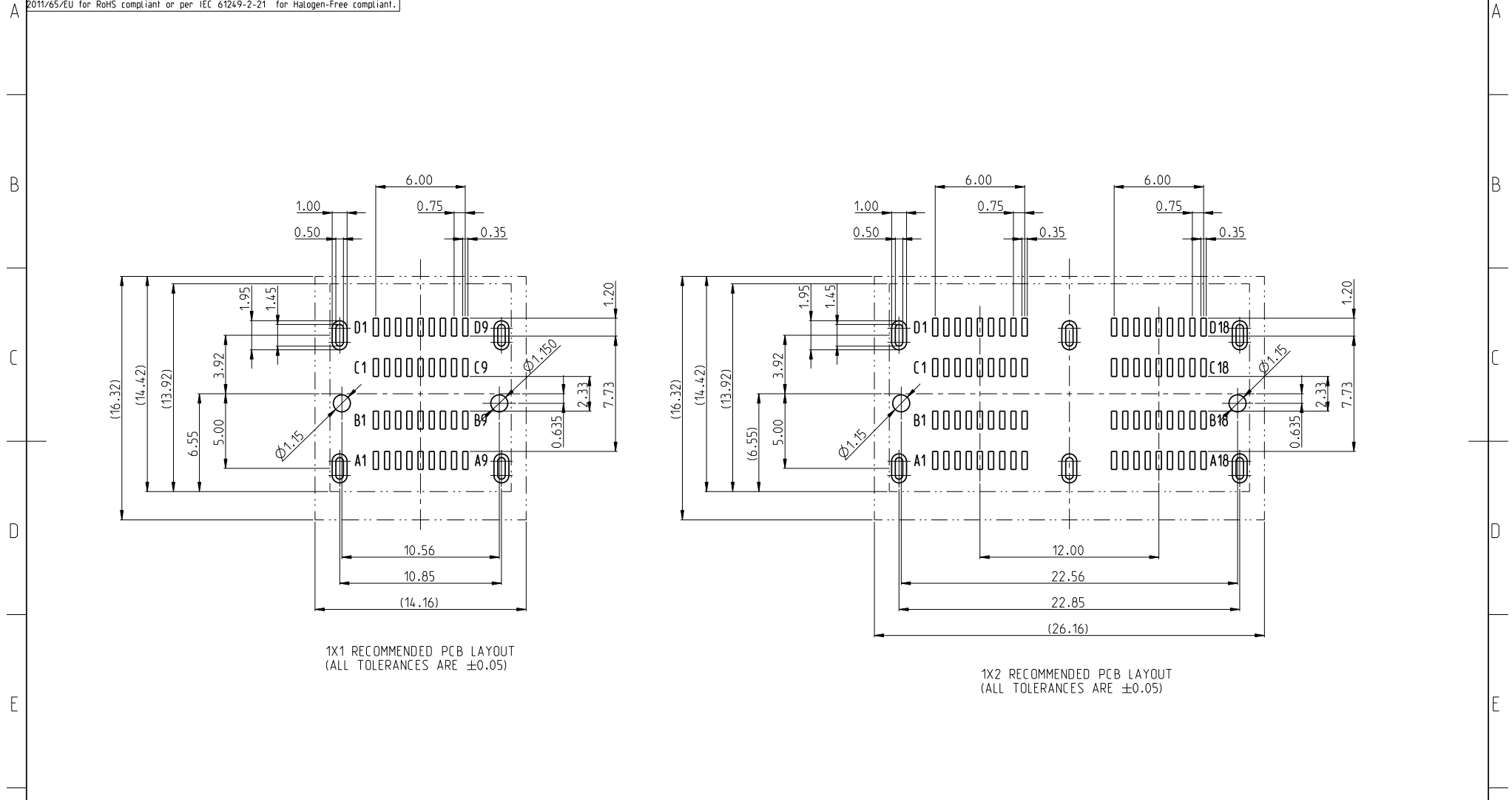

TOLERANCE	DRAWN	APPROVALS	DATE	TITLE				
X.		DESIGNED	09/13/2013	MINI SAS HD	Amphenol Corporation Amphenol Taiwan Corporation			
X.X ±0.30		Hank Hsu		INTEGRATED CONNECTOR				
X.XX ±0.20		CHECKED	09/13/2013	0.75 PITCH, V/T,				
X.XXX ±0.10		Sondra Sang		SMT TYPE	UNIT	mm	SIZE	A3
ANGULAR ±2°		APPROVED	09/13/2013		SCALE	NA	SHEET	3 OF 3
UNLESS OTHERWISE SPECIFIED		DWG TYPE	CUST DWG	PROJECT CODE	PART No. G40H4XXXXXXHR DWG No. G40H4XXXXXXHR REV. AX3			
				1515				